

FOOTING A

Height of Wall	Width of Footing
3'-4"	18"
5'	24"
6'	26"

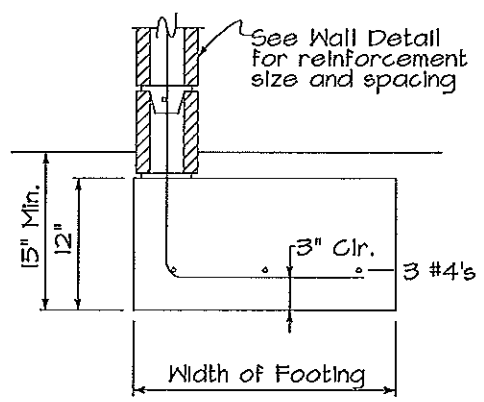

FOOTING B

Height of Wall	Width of Footing
3'-4"	22"
5'	30"
6'	34"

ALTERNATE FOOTING B

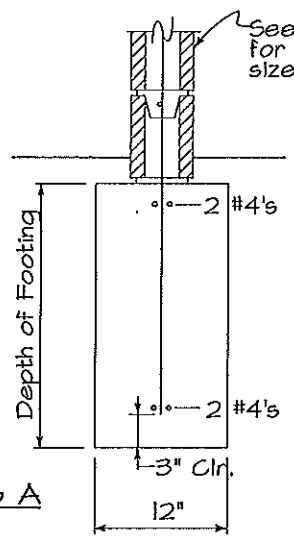

FOOTING C

Height of Wall	Depth of Footing
3'-4"	24"
5'	29"
6'	32"

ALTERNATE FOOTING C

MASONRY FENCE DETAIL & ALTERNATE FOOTING A

GENERAL NOTES

1. Concrete blocks shall be Grade N units.
2. Use f'c = 4500 psi for concrete footing. Type V
3. Reinforcing steel shall be A615 Grade 40 or 60.
4. Fill all cells containing steel with grout, including bond beam.
5. The wall shall be plumb and all block courses shall be level.
6. Reinforcing steel splices shall be a minimum of 24".
7. The first course may be set in fresh concrete for footing.
8. No wall or fence shall be allowed within 36" of a fire hydrant and no wall, fence, or foundation shall be allowed within 12" of a water meter.
9. Planning regulates the height, location, and design of the wall based on the zone, location on the property, and community design standards. Planning must approve the plans prior to any permit being issued.

REINFORCING STEEL TABLE

Height of Wall	Vertical Steel
5'-0" or less	#4 @ 32" o.c.
6'-0" or less	#4 @ 24" o.c.

NOTE: This wall is not designed to be used for a retaining wall



BLOCK GARDEN WALL

**HELP FOR THE HOMEOWNER
FOUNTAIN VALLEY BUILDING AND SAFETY**

Building Official:	Date
DATE: 1/1/08	SHEET 1 OF 1 B801

MASONRY PILASTER

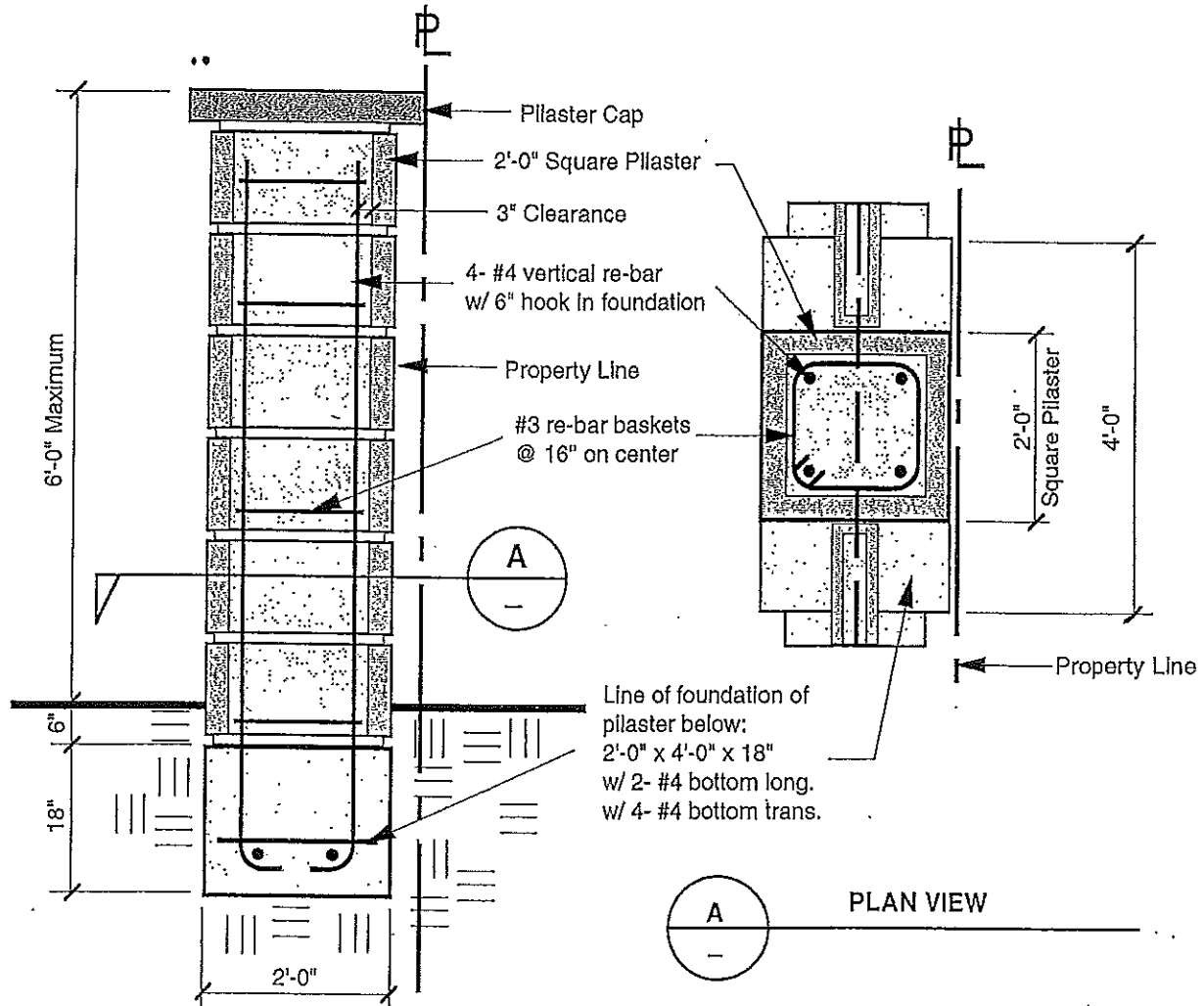

Notes:

1. All cells shall be filled solid with grout. (See concrete masonry specifications on reverse side).
2. No special inspection is required.

SHOW THE SET BACKS, DISTANCE BETWEEN ALL PROPERTY LINES AND NEW BLOCK WALLS.
 INCLUDE SET BACKS FROM NEIGHBORS IF THIS IS A WALL BETWEEN TWO PROPERTIES.

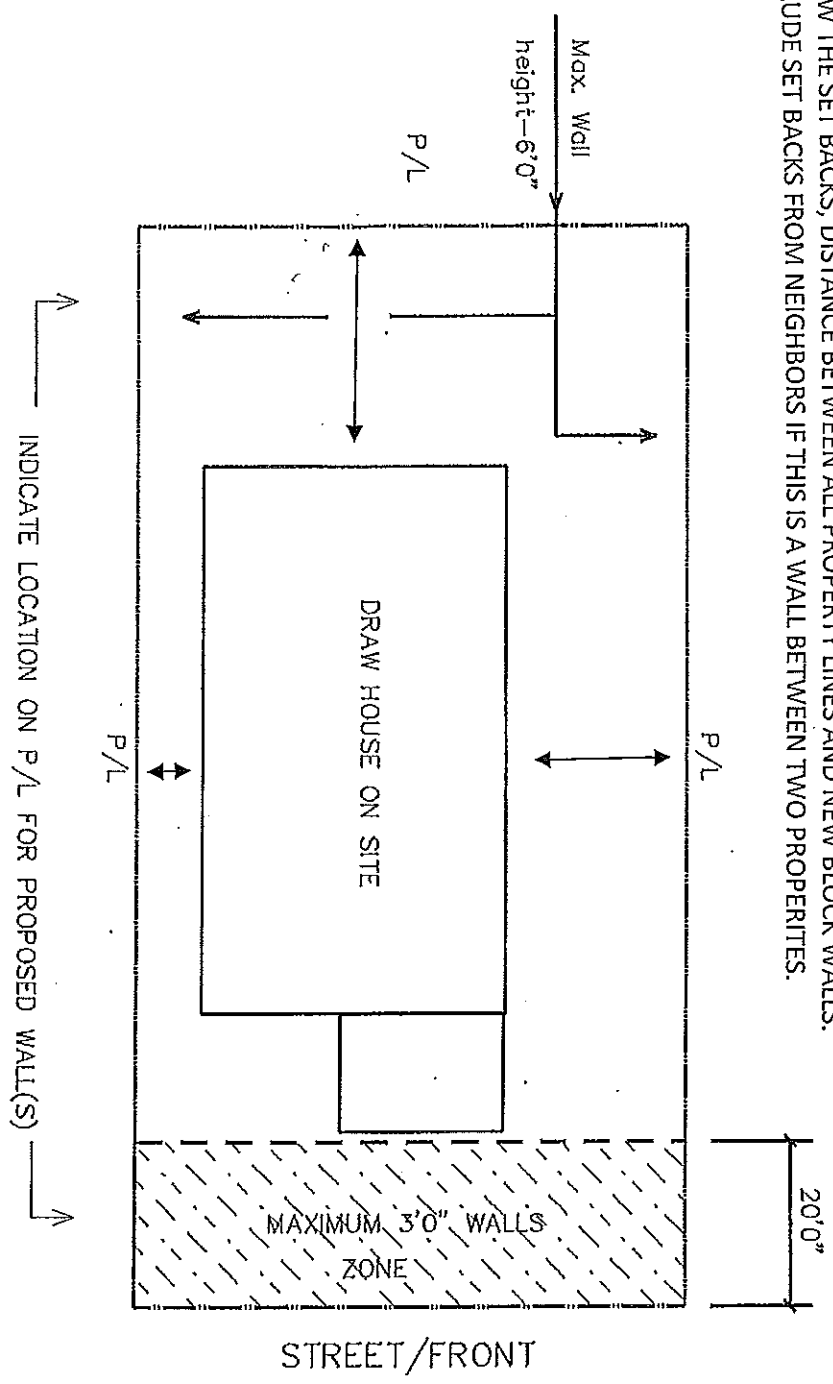

NOTES:

- *NO WALLS OVER 3'0" WITHIN FRONT SETBACK AREA.
- *MAXIMUM FENCE/WALL HEIGHT IS 6'0"
- *PROPERTY OWNER'S SIGNATURES ON ADJACENT LOTS TO POPOSED WALL ARE REQUIRED.

PROPERTY OWNER'S SIGNATURE _____

ADJACENT OWNER'S SIGNATURE _____

ADJACENT OWNER'S SIGNATURE _____

ADJACENT OWNER'S SIGNATURE _____

ADJACENT OWNER'S SIGNATURE _____

BLOCK WALL PERMIT APPLICATION

Lot Profile/Wall and Fence Height

CITY OF FOUNTAIN VALLEY

