

SECTION 100
STREET IMPROVEMENTS

PLAN NO. DESCRIPTION

| | |
|-------|---|
| 100 | TOPOGRAPHY SYMBOLS |
| 101 | SIX LANE DIVIDED MAJOR ARTERIAL HIGHWAY |
| 102 | FOUR LANE DIVIDED PRIMARY ARTERIAL HIGHWAY |
| 103 | FOUR LANE DIVIDED SECONDARY ARTERIAL HIGHWAY |
| 104 | FOUR LANE UNDIVIDED SECONDARY ARTERIAL HIGHWAY |
| 105 | COLLECTOR HIGHWAY |
| 106 | RAISED MEDIAN TYPICAL SECTION |
| 107 | STANDARD CUL DE SAC |
| 108 | MODIFIED SYMMETRICAL CUL DE SAC |
| 109 | OFFSET CUL DE SAC |
| 110 | STANDARD KNUCKLE |
| 111 | PARABOLIC CURB TRANSITION FOR LEFT TURN POCKETS |
| 112 | PARABOLIC MEDIAN CURB FLARE |
| 113 | MEDIAN NOSE PAVING DETAIL |
| 114 | FRONTAGE ROAD MEDIAN ISLAND NOSE |
| 115-1 | MEDIAN CURB |
| 115-2 | RAISED MEDIAN NOSE LOCATION |
| 116 | CONCRETE CLASS USE TABLE |
| 117 | STREET DESILTING SANDBAGGING |
| 118 | DIVIDER MEDIAN |
| 119 | SWALE SANDBAG VELOCITY REDUCERS |
| 120 | STREET ASPHALT PATCHING FOR TRENCH EXCAVATIONS |
| 121 | STEEL PLATE BENCHING DETAIL |

TOPOGRAPHIC SYMBOLS

| | | |
|---|---|---|
| <p>○ TELEPHONE POLE</p> <p>● EDISON POLE</p> <p>← GUY WIRE</p> <p>⊙ SEWER MANHOLE</p> <p>⊙ STORM DRAIN MANHOLE</p> <p>⊗ FIRE HYDRANT</p> <p>● SPRINKLER HEAD</p> <p>┆ HOSE BIB</p> <p>⊙ IRRIGATION STANDPIPE</p> <p>⊠ WATER WELL</p> <p>⊗ WATER VALVE</p> <p>□ WATER METER</p> <p>⊠ GAS METER</p> <p>⊠ W WATER VAULT</p> <p>⊠ G GAS VAULT</p> <p>⊠ T TELEPHONE VAULT</p> <p>⊠ E EDISON VAULT</p> <p>⊙ BM BENCH MARK</p> | <p>▨ MAIL BOX</p> <p>┆ STREET SIGN</p> <p>⊙ STREET LIGHT</p> <p>⊙ TRAFFIC SIGNAL</p> <p>⊠ PEDESTRIAN SIGNAL</p> <p>⊠ TRAFFIC SIGNAL CONTROLLER</p> <p>□ PULL BOX</p> <p>⊠ FIRE ALARM BOX</p> <p>⊙ R/R RAILROAD CROSSING SIGNAL</p> <p>⊙ TREE</p> <p>✻ PALM TREE</p> <p>☁ SHRUB</p> <p>▬ GUARD RAIL</p> <p>▬ CONCRETE BLOCK WALL</p> <p>○-○ WOOD FENCE</p> <p>x-x-x CHAIN LINK FENCE</p> <p>/// EDGE OF EXISTING A.C. PAVEMENT</p> <p>▨ EXISTING CONCRETE SURFACE</p> <p>⌒ CURB RAMP</p> | <p>MAIL BOX</p> <p>STREET SIGN</p> <p>STREET LIGHT</p> <p>TRAFFIC SIGNAL</p> <p>PEDESTRIAN SIGNAL</p> <p>TRAFFIC SIGNAL CONTROLLER</p> <p>PULL BOX</p> <p>FIRE ALARM BOX</p> <p>RAILROAD CROSSING SIGNAL</p> <p>TREE</p> <p>PALM TREE</p> <p>SHRUB</p> <p>GUARD RAIL</p> <p>CONCRETE BLOCK WALL</p> <p>WOOD FENCE</p> <p>CHAIN LINK FENCE</p> <p>EDGE OF EXISTING A.C. PAVEMENT</p> <p>EXISTING CONCRETE SURFACE</p> <p>CURB RAMP</p> |
|---|---|---|

LINE SYMBOLS

| | |
|-----------------------|----------------|
| STREET CENTERLINE | ————— |
| RIGHT-OF-WAY | ————— |
| PROPOSED IMPROVEMENTS | ————— |
| EXISTING IMPROVEMENTS | ————— |
| FUTURE IMPROVEMENTS | ————— |
| STORM DRAIN | —————SD————— |
| SANITARY SEWER | —————S————— |
| WATER | —————W————— |
| RECLAIMED WATER | —————RW————— |
| GAS | —————G————— |
| TELEPHONE | —————T————— |
| ELECTRIC | —————E————— |
| SIGNAL INTERCONNECT | —————SI————— |
| CABLE TV | —————CATV————— |

REVISIONS

CITY OF FOUNTAIN VALLEY

STANDARD
PLAN NO.

TOPOGRAPHIC SYMBOLS

100

APPROVED BY: MARK LEWIS R.C.E. 49335
CITY ENGINEER

DATE: 06/03/03

SHEET: 1 OF 1

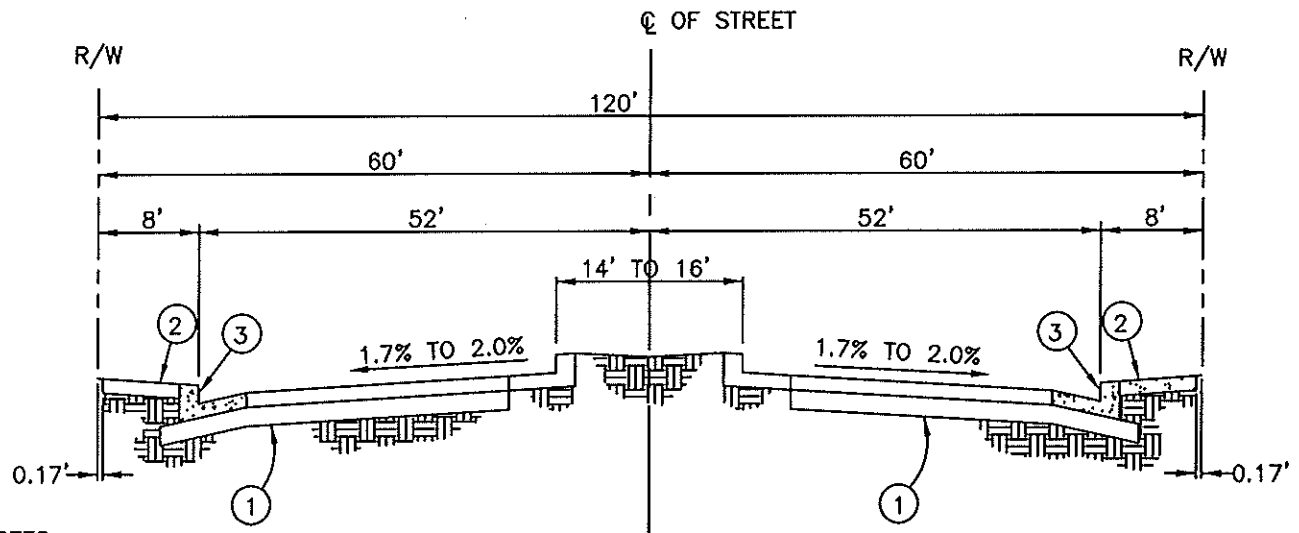

NOTES:

- ① STRUCTURAL SECTION TO BE DETERMINED BY R-VALUE TEST AND 20 YEAR TRAFFIC INDEX. MINIMUM OF 0.40' A.C. OVER 0.83' A.B.
- ② SIDEWALK PER STD. PLAN 201.
- ③ CURB AND GUTTER PER STD. PLAN 200.

GENERAL NOTES:

- 1. MINIMUM LONGITUDINAL GRADE SHALL BE 0.50% UNLESS OTHERWISE APPROVED.
- 2. STREET PARKING GENERALLY NOT PROVIDED.

MAJOR ARTERIALS

WARNER AVENUE, HARBOR BLVD. AND BROOKHURST STREET

NOTES :

- 1. SEE STANDARD PLAN NO. 200 FOR CURB AND GUTTER DETAILS.
- 2. STRUCTURAL SECTION TO BE DETERMINED BY SOILS TESTS AND APPROVED BY THE CITY ENGINEER.
- 3. EXACT WIDTH OF ROADWAY AND PARKWAY TO BE DETERMINED BY THE CITY ENGINEER. AN ADDITIONAL 12' LANE MAY BE REQUIRED.
- 4. LANDSCAPING OF MEDIAN AND PARKWAY AS REQUIRED BY THE CITY ENGINEER.
- 5. SIDEWALK IN PARKWAY AS REQUIRED BY THE CITY ENGINEER.
- 6. FINISHED SURFACE OF PAVEMENT SHALL BE 3/8" ABOVE LIP OF GUTTER & FLUSH WITH LIP OF MEDIAN GUTTER.
- 7. MOISTURE BARRIERS SHALL BE REQUIRED AS SHOWN ON STANDARD PLAN NO. 218 UNLESS OTHERWISE APPROVED BY THE CITY ENGINEER.
- 8. CROSS FALL WILL INCREASE WITH ADDITIONAL PAVING/OVERLAYS

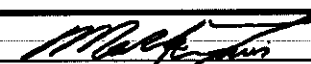
| | | |
|-----------|--|--|
| REVISIONS | CITY OF FOUNTAIN VALLEY | STANDARD PLAN NO. 101 |
| | SIX LANE DIVIDED MAJOR ARTERIAL HIGHWAY TYPICAL SECTION | |
| |  APPROVED BY: MARK LEWIS R.C.E. 49335 CITY ENGINEER | |
| | DATE: 06/03/03 | SHEET: 1 OF 1 |

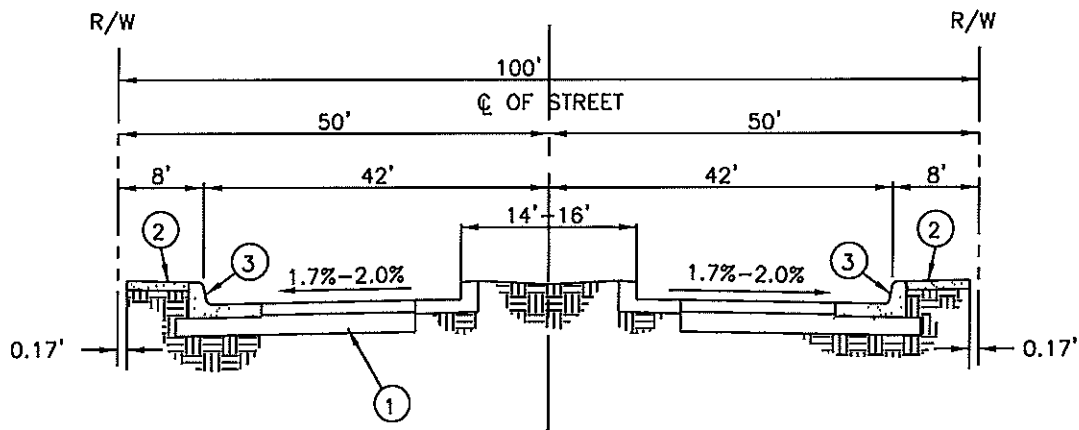

NOTES:

- ① STRUCTURAL SECTION TO BE DETERMINED BY R-VALUE TEST AND 20 YEAR TRAFFIC INDEX. MINIMUM SECTION 0.40' A.C. OVER 0.83' A.B.
- ② SIDEWALK PER STD. PLAN 201.
- ③ CURB AND GUTTER PER STD. PLAN 200.

GENERAL NOTES:

- 1. MINIMUM LONGITUDINAL GRADE SHALL BE 0.50% UNLESS OTHERWISE APPROVED.
- 2. STREET PARKING AVAILABLE IN SAME SECTION.
- 3. BIKE TRAIL NOT PROVIDED (ADDITIONAL 7' EACH SIDE IF REQUIRED).

PRIMARY ARTERIAL:

EDINGER AVENUE, SLATER AVENUE(1-405 - WARD STREET) TALBERT AVENUE, GARFIELD AVENUE, MAGNOLIA STREET AND EUCLID STREET, (EUCLID STREET AND TALBERT AVENUE CONTAIN SECTIONS OF SIX-LANE DIVIDED PRIMARY HIGHWAY).

NOTES :

- 1. SEE STANDARD PLAN NO. 200 FOR CURB AND GUTTER DETAILS.
- 2. STRUCTURAL SECTION TO BE DETERMINED BY SOILS TESTS AND APPROVED BY THE CITY ENGINEER.
- 3. EXACT WIDTH OF ROADWAY AND PARKWAY TO BE DETERMINED BY THE CITY ENGINEER. AN ADDITIONAL 12' LANE MAY BE REQUIRED.
- 4. LANDSCAPING OF MEDIAN AND PARKWAY AS REQUIRED BY THE CITY ENGINEER.
- 5. SIDEWALK IN PARKWAY AS REQUIRED BY THE CITY ENGINEER.
- 6. FINISHED SURFACE OF PAVEMENT SHALL BE 3/8" ABOVE LIP OF GUTTER & FLUSH WITH LIP OF MEDIAN GUTTER.
- 7. MOISTURE BARRIERS SHALL BE REQUIRED AS SHOWN ON STANDARD PLAN NO. 218 UNLESS OTHERWISE APPROVED BY THE CITY ENGINEER.
- 8. CROSS FALL WILL INCREASE WITH ADDITIONAL PAVING/OVERLAYS

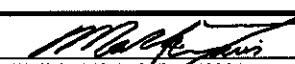
| | | |
|------------------|--|---|
| REVISIONS | CITY OF FOUNTAIN VALLEY | STANDARD PLAN NO. 102 |
| 10/10/07 | FOUR LANE DIVIDED PRIMARY ARTERIAL HIGHWAY TYPICAL SECTION | |
| |  APPROVED BY: MARK LEWIS R.C.E. 49335 CITY ENGINEER | |
| | DATE: 06/03/03 | SHEET: 1 OF 1 |

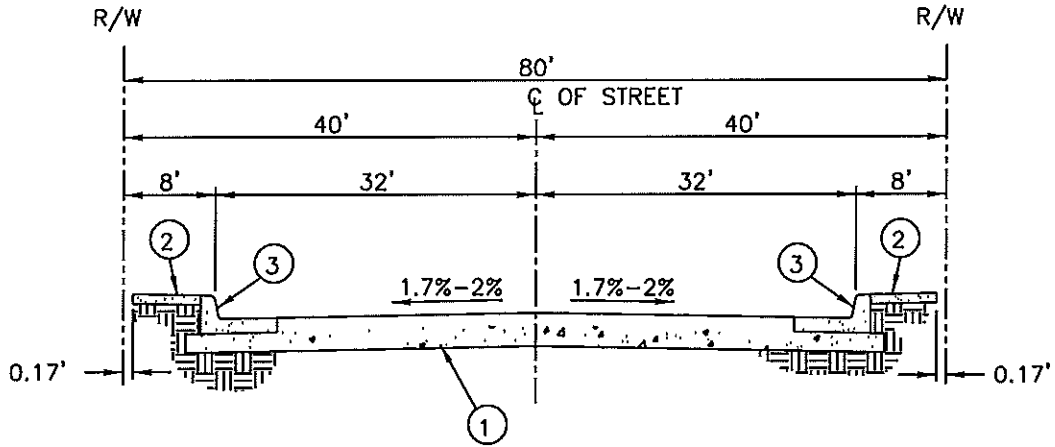

NOTES:

- ① STRUCTURAL SECTION TO BE DETERMINED BY R-VALUE TEST AND 20 YEAR TRAFFIC INDEX. MINIMUM SECTION 0.40' A.C. OVER 0.83' A.B.
- ② SIDEWALK PER STD. PLAN 201.
- ③ CURB AND GUTTER PER STD. PLAN 200.

GENERAL NOTES:

- 1. MINIMUM LONGITUDINAL GRADE SHALL BE 0.50% UNLESS OTHERWISE APPROVED.
- 2. STREET PARKING NOT PROVIDED

SECONDARY ARTERIAL:

BUSHARD STREET, WARD STREET (EXCEPT FROM SLATER AVENUE TO WARNER AVENUE), NEWHOPE STREET (EXCEPT FROM EUCLID STREET TO TALBERT AVENUE), HEIL AVENUE, SLATER AVENUE (EXCEPT FROM 1405 TO WARD STREET), ELLIS AVENUE AND NEWLAND STREET.

NOTES :

- 1. SEE STANDARD PLAN NO. 200 FOR CURB AND GUTTER DETAILS.
- 2. STRUCTURAL SECTION TO BE DETERMINED BY SOILS TESTS AND APPROVED BY THE CITY ENGINEER.
- 3. EXACT WIDTH OF ROADWAY AND PARKWAY TO BE DETERMINED BY THE CITY ENGINEER. AN ADDITIONAL 12' LANE MAY BE REQUIRED.
- 4. LANDSCAPING OF MEDIAN AND PARKWAY AS REQUIRED BY THE CITY ENGINEER.
- 5. SIDEWALK IN PARKWAY AS REQUIRED BY THE CITY ENGINEER.
- 6. FINISHED SURFACE OF PAVEMENT SHALL BE 3/8" ABOVE LIP OF GUTTER & FLUSH WITH LIP OF MEDIAN GUTTER.
- 7. MOISTURE BARRIERS SHALL BE REQUIRED AS SHOWN ON STANDARD PLAN NO. 218 UNLESS OTHERWISE APPROVED BY THE CITY ENGINEER.
- 8. CROSS FALL WILL INCREASE WITH ADDITIONAL PAVING/OVERLAYS

| | | |
|-----------|--|--|
| REVISIONS | CITY OF FOUNTAIN VALLEY | STANDARD PLAN NO. 103 |
| 10/10/07 | FOUR LANE DIVIDED SECONDARY ARTERIAL HIGHWAY TYPICAL SECTION | |
| | | |
| | APPROVED BY:  MARK LEWIS R. O. E. 49335 CITY ENGINEER | DATE: 06/03/03 |
| | | SHEET: 1 OF 1 |

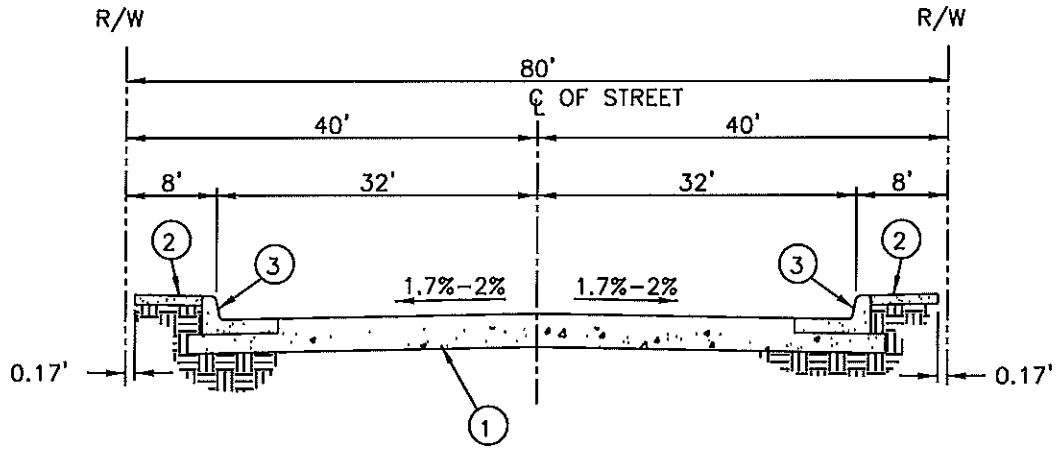

NOTES:

- ① STRUCTURAL SECTION TO BE DETERMINED BY R-VALUE TEST AND 20 YEAR TRAFFIC INDEX. MINIMUM SECTION 0.40' A.C. OVER 0.83' A.B.
- ② SIDEWALK PER STD. PLAN 201.
- ③ CURB AND GUTTER PER STD. PLAN 200.

GENERAL NOTES:

- 1. MINIMUM LONGITUDINAL GRADE SHALL BE 0.50% UNLESS OTHERWISE APPROVED.
- 2. STREET PARKING NOT PROVIDED

SECONDARY ARTERIAL:

WARD STREET FROM SLATER AVENUE TO WARNER AVENUE.

NOTES :

- 1. SEE STANDARD PLAN NO. 200 FOR CURB AND GUTTER DETAILS.
- 2. STRUCTURAL SECTION TO BE DETERMINED BY SOILS TESTS AND APPROVED BY THE CITY ENGINEER.
- 3. EXACT WIDTH OF ROADWAY AND PARKWAY TO BE DETERMINED BY THE CITY ENGINEER. AN ADDITIONAL 12' LANE MAY BE REQUIRED.
- 4. LANDSCAPING OF MEDIAN AND PARKWAY AS REQUIRED BY THE CITY ENGINEER.
- 5. SIDEWALK IN PARKWAY AS REQUIRED BY THE CITY ENGINEER.
- 6. FINISHED SURFACE OF PAVEMENT SHALL BE 3/8" ABOVE LIP OF GUTTER & FLUSH WITH LIP OF MEDIAN GUTTER.
- 7. MOISTURE BARRIERS SHALL BE REQUIRED AS SHOWN ON STANDARD PLAN NO. 218 UNLESS OTHERWISE APPROVED BY THE CITY ENGINEER.
- 8. CROSS FALL WILL INCREASE WITH ADDITIONAL PAVING/OVERLAYS

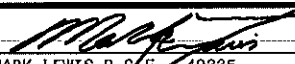
| | | |
|------------------|--|---|
| REVISIONS | CITY OF FOUNTAIN VALLEY | STANDARD PLAN NO. 104 |
| 10/10/07 | FOUR LANE UNDIVIDED SECONDARY ARTERIAL HIGHWAY TYPICAL SECTION | |
| |  APPROVED BY: MARK LEWIS R. C. E. 49335 CITY ENGINEER | |
| | DATE: 06/03/03 | SHEET: 1 OF 1 |

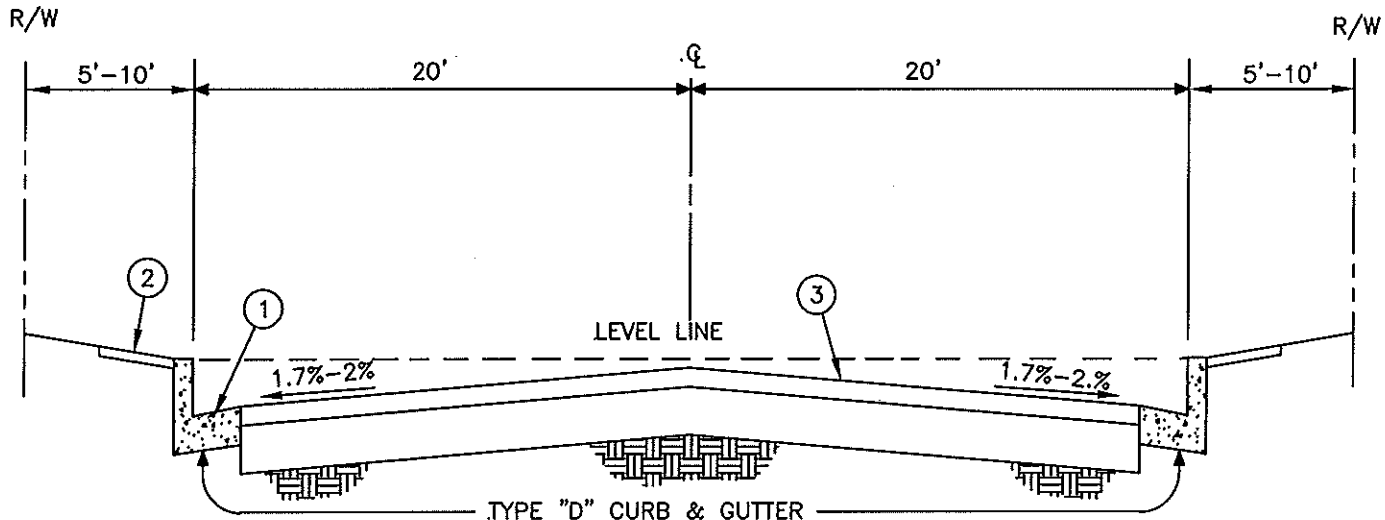

- ① SEE STANDARD NO. 200 FOR CURB AND GUTTER DETAIL.
- ② SEE STANDARD NO. 201 FOR SIDEWALK REQUIREMENTS AND DETAILS.
- ③ STRUCTURAL SECTION TO BE DETERMINED BY SOIL TEST AND APPROVED BY THE CITY ENGINEER.

NOTES :

1. EXACT WIDTH OF ROADWAY AND PARKWAY TO BE DETERMINED BY THE CITY ENGINEER.
2. LANDSCAPING AND SIDEWALK IN PARKWAY AS REQUIRED BY THE CITY ENGINEER.
3. MOISTURE BARRIERS SHALL BE REQUIRED AS SHOWN ON STD.PLAN NO. 218 UNLESS OTHERWISE APPROVED BY CITY ENGINEER.
4. FINISHED SURFACE OF PAVEMENT SHALL BE 3/8" ABOVE LIP OF GUTTER.
5. DISTANCE OF CROWN BELOW LEVEL LINE IS 0.06'.

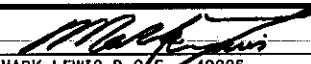
| | | |
|-----------|--|--|
| REVISIONS | CITY OF FOUNTAIN VALLEY | STANDARD PLAN NO. 105 |
| | COLLECTOR HIGHWAY | |
| |  APPROVED BY: MARK LEWIS R.C.E. 49335 CITY ENGINEER | DATE: 06/03/03 |
| | | SHEET: 1 OF 1 |

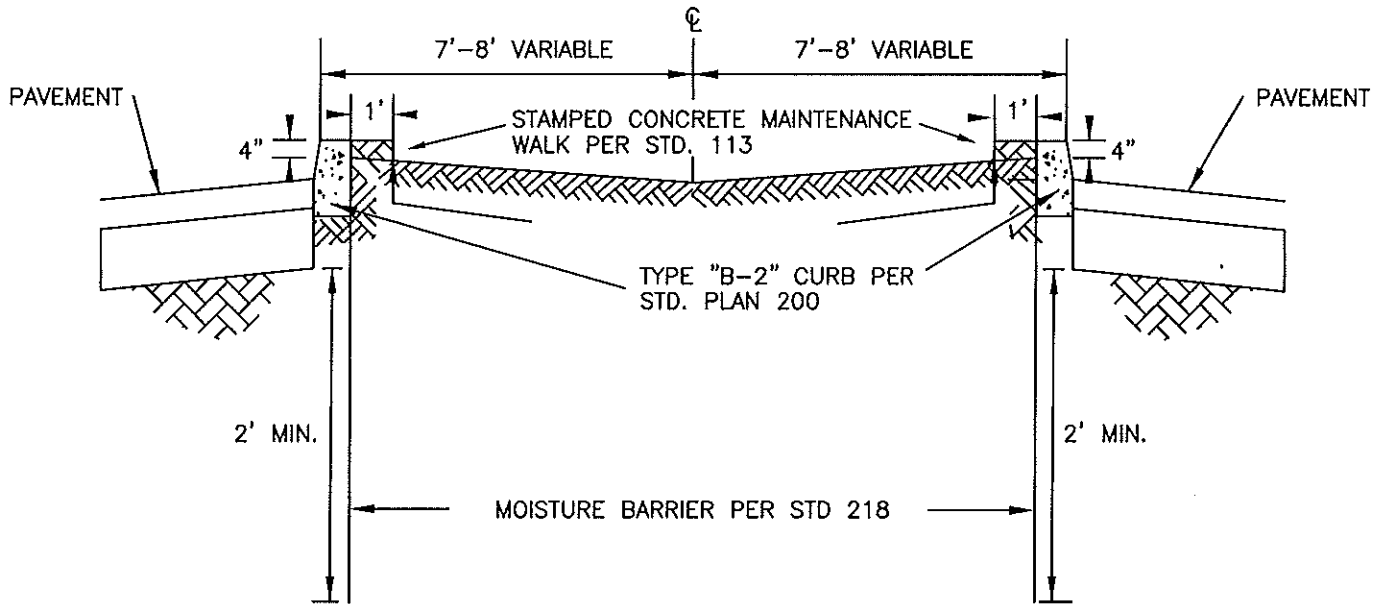

NOTES:

1. MEDIAN AREAS LESS THAN 3' WIDE SHALL BE SOLID PCC PAVED MONOLITHICALLY PER STD. PLAN NO. 113.
2. ALL LANDSCAPING AND IRRIGATING DEVICES SHALL BE APPROVED BY THE PUBLIC WORKS DEPARTMENT PRIOR TO INSTALLATION
3. SOIL MATERIALS WITHIN LANDSCAPED MEDIAN SHALL BE SUITABLE FOR PLANTING AND APPROVED BY THE PUBLIC WORKS DEPARTMENT
4. IMPERMEABLE MEMBRANE SHALL BE 20 MIL. POLYETHYLENE OR APPROVED EQUAL. MEMBRANE IS NOT NECESSARY IF MEDIAN IS FILLED WITH STAMPED CONCRETE.

| | | |
|--------------|--|----------------------|
| REVISIONS | CITY OF FOUNTAIN VALLEY | STANDARD PLAN NO. |
| 06/08/06 | RAISED MEDIAN TYPICAL SECTION | |
| | <i>Mark Lewis</i> | 106 |
| APPROVED BY: | MARK LEWIS R.C.E. 49335 CITY ENGINEER | DATE: 06/03/03 |
| | | SHEET: 1 OF 1 |

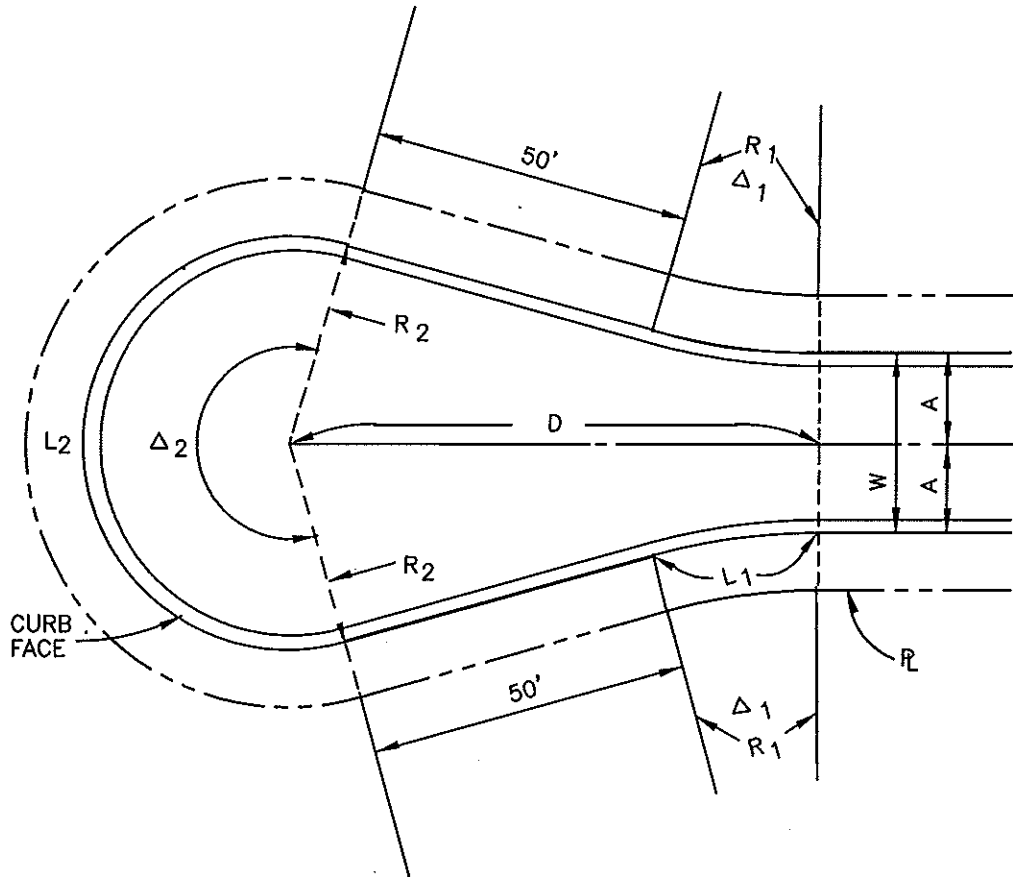

| A | Δ_1 | R_1 | L_1 | T_1 | Δ_2 | R_2 | L_2 | D |
|-----|------------|-------|--------|--------|------------|-------|---------|--------|
| 14' | 19°07'34" | 100' | 33.38' | 16.85' | 218°15'08" | 38' | 144.75' | 92.46' |
| 18' | 16°34'35" | 100' | 28.93' | 14.57' | 213°09'10" | 38' | 141.37' | 87.29' |
| 20' | 15°14'33" | 100' | 26.60' | 13.38' | 210°29'07" | 38' | 139.60' | 84.52' |
| | | | | | | | | |
| | | | | | | | | |

| | | |
|-----------|--|--|
| REVISIONS | CITY OF FOUNTAIN VALLEY | STANDARD PLAN NO. 107 |
| | STANDARD-CUL-DE-SAC | |
| | APPROVED BY: MARK LEWIS R.C.E. 49335 CITY ENGINEER | DATE: 06/03/03 |
| | SHEET: 1 OF 1 | |

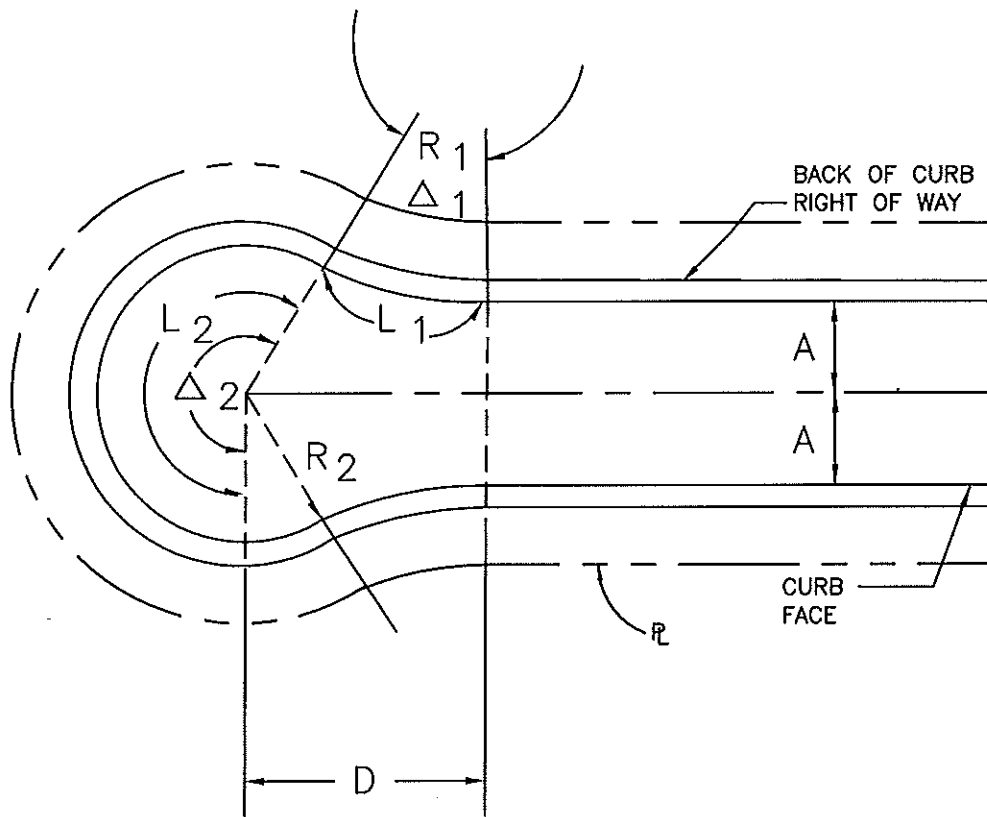

| A | Δ_1 | R_1 | L_1 | T_1 | Δ_2 | R_2 | L_2 | D |
|-----|-------------|-------|--------|--------|--------------|-------|---------|--------|
| 18' | 16° 57' 27" | 100' | 54.51' | 27.95' | 242° 27' 52" | 38' | 160.81' | 71.55' |
| 20' | 27° 51' 51" | 100' | 51.65' | 26.41' | 239° 11' 01" | 38' | 158.63' | 68.15' |
| 22' | 29° 35' 31" | 100' | 48.63' | 24.81' | 235° 43' 42" | 38' | 156.34' | 64.50' |
| 32' | 31° 13' 56" | 100' | 29.60' | 14.91' | 213° 54' 53" | 38' | 141.87' | 40.25' |
| | | | | | | | | |

NOTES :

1. "A" IS MEASURED FROM CURB FACE TO CENTERLINE.
2. WHEN THERE ARE MORE THAN SIX ACCESSES AROUND THE CUL-DE-SAC, USE STD. PLAN No. 107.

REVISIONS

CITY OF FOUNTAIN VALLEY

MODIFIED SYMMETRICAL CUL-DE-SAC

STANDARD
PLAN NO.

108

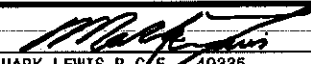
APPROVED BY: 
MARK LEWIS R.C.E. 49335
CITY ENGINEER

DATE: 06/03/03

SHEET: 1 OF 1

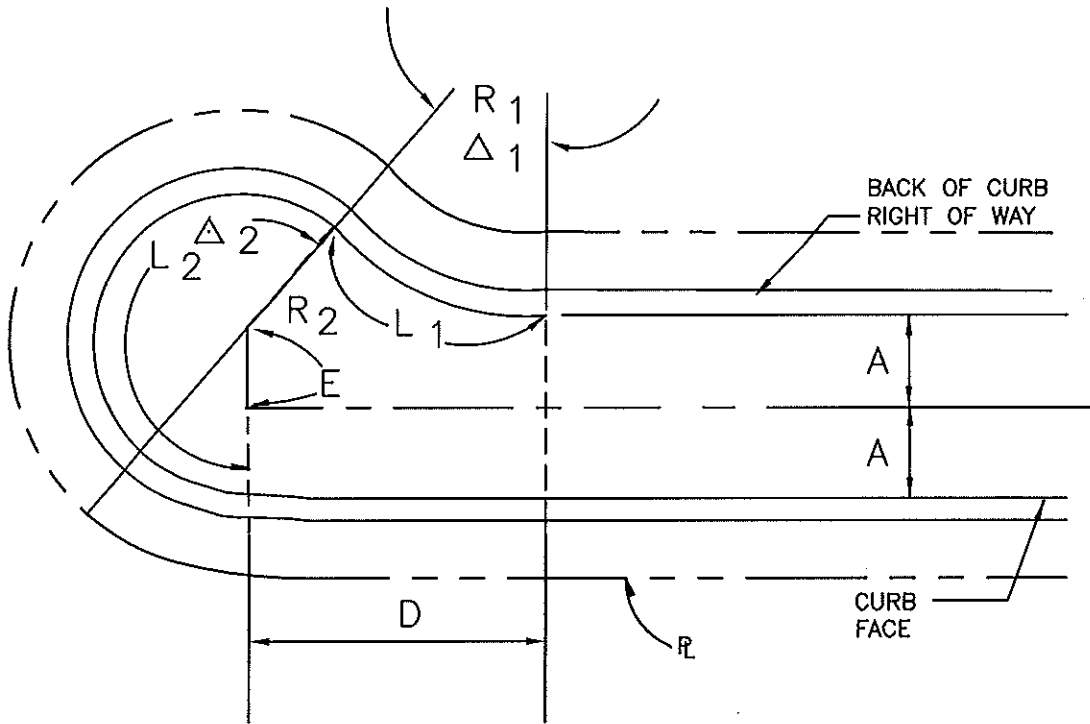

| A | Δ_1 | R_1 | L_1 | T_1 | Δ_2 | R_2 | L_2 | D | E |
|-----|-------------|-------|--------|--------|--------------|-------|---------|--------|-----|
| 18' | 50° 58' 38" | 70' | 62.28' | 33.37' | 230° 58' 38" | 38' | 153.19' | 83.90' | 20' |
| 20' | 48° 11' 23" | 70' | 58.87' | 31.30' | 228° 11' 23" | 38' | 151.34' | 80.50' | 18' |
| 22' | 45° 16' 31" | 70' | 55.31' | 29.19' | 225° 16' 31" | 38' | 149.41' | 76.73' | 16' |
| 32' | 27° 15' 58" | 70' | 33.31' | 16.98' | 207° 15' 58" | 38' | 137.46' | 49.42' | 6' |
| | | | | | | | | | |

NOTES:

1. RADIAL POINT MAY BE OFFSET EITHER RIGHT OR LEFT OF CENTERLINE.
2. "A" IS MEASURED FROM CURB FACE TO CENTERLINE.
3. WHEN THERE ARE MORE THAN SIX ACCESSES AROUND THE CUL-DE-SAC, USE STD. PLAN No. 107.

REVISIONS

CITY OF FOUNTAIN VALLEY

OFFSET CUL-DE-SAC

STANDARD
PLAN NO.

109

APPROVED BY:  MARK LEWIS R.C.E. 49335
CITY ENGINEER

DATE: 06/03/03

SHEET: 1 OF 1

CURVE DATA

CURB RADIUS = 50'
 PL RADIUS = 50' - P_s

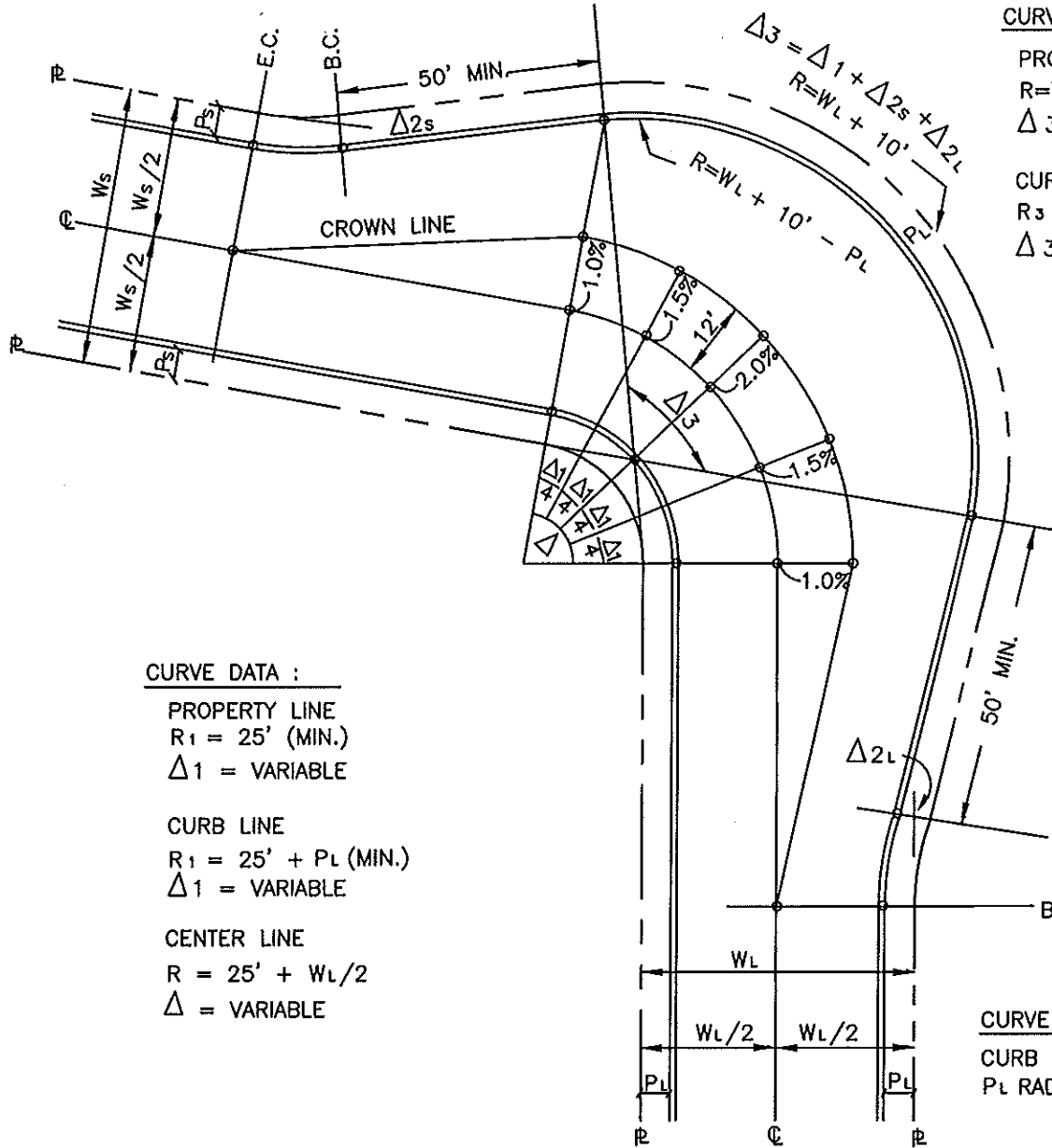

CURVE DATA

PROPERTY LINE
 $R = W_L + 10'$
 $\Delta 3 = \Delta 1 + \Delta 2_s + \Delta 2_l$

CURB LINE
 $R = W_L + 10' - P_L$
 $\Delta 3 = \Delta 1 + \Delta 2_s + \Delta 2_l$

CURVE DATA :

PROPERTY LINE
 $R_1 = 25'$ (MIN.)
 $\Delta 1 =$ VARIABLE

CURB LINE
 $R_1 = 25' + P_L$ (MIN.)
 $\Delta 1 =$ VARIABLE

CENTER LINE
 $R = 25' + W_L/2$
 $\Delta =$ VARIABLE

CURVE DATA

CURB RADIUS = 50'
 PL RADIUS = 50' - P_L

NOTES:

1. KNUCKLES ARE LIMITED TO CUL-DE-SAC STREETS OR MUST RECEIVE PRIOR APPROVAL BY THE CITY ENGINEER.
2. USE NORMAL SECTION FROM INNER CURB TO CENTER LINE.
3. FROM CROWN LINE TO CURB, THE MAXIMUM SLOPE IS 1" PER FOOT.
4. SUPER ELEVATION PERCENTAGES SHOWN ARE A STRAIGHT GRADE FROM CENTER LINE TO CROWN LINE.
5. ELEVATIONS ARE REQUIRED WHERE CIRCLED (o).
6. WHEN STREETS ARE SUPER ELEVATED, THE CROWN LINE WILL NOT NECESSARILY TERMINATE ON CENTER LINE AT ANGLE POINT OF CURB.
7. SUBSCRIPTS "S" AND "L" DENOTE SMALLER AND LARGER STREETS RESPECTIVELY.

REVISIONS

CITY OF FOUNTAIN VALLEY

STANDARD
 PLAN NO.

STANDARD KNUCKLE

110

APPROVED BY:  MARK LEWIS R.C.E. 49335
 CITY ENGINEER

DATE: 06/03/03

SHEET: 1 OF 1

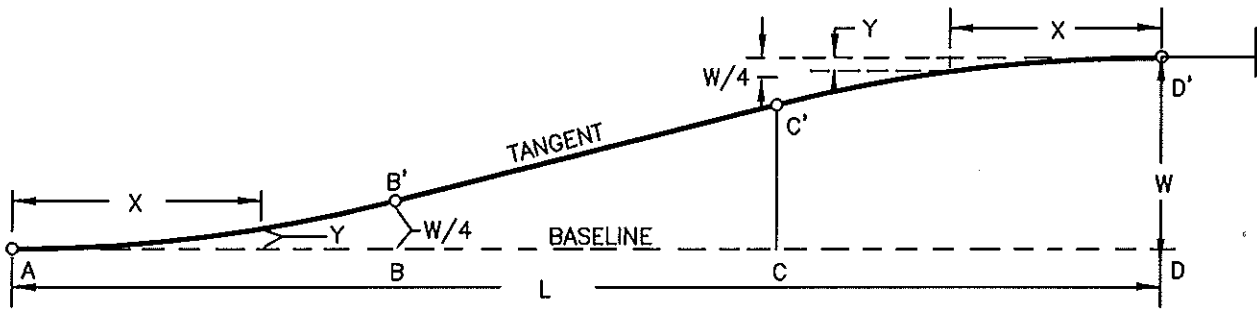

W = WIDTH OF LEFT TURN POCKET
 L = LENGTH OF TAPER
 X = DISTANCE FROM POINT "A" ALONG BASE LINE
 Y = OFFSET FROM BASE LINE
 AB = BC = CD = L/3
 AB' AND C'D' ARE PARABOLIC CURVES EXCEPT ON CURVED ALIGNMENTS

SINGLE LEFT TURN POCKET

L=90' W=10'

| | | | | | | | | | | |
|---|-------|-------|-------|-------|-------|-------|-------|-------|-------|--------|
| X | 0' | 10' | 20' | 30' | 40' | 50' | 60' | 70' | 80' | 90' |
| Y | 0.00' | 0.28' | 1.11' | 2.50' | 4.17' | 5.83' | 7.50' | 8.89' | 9.72' | 10.00' |

DOUBLE LEFT TURN POCKET

L=150' W=20'

| | | | | | | | | |
|---|-------|-------|-------|-------|-------|-------|-------|-------|
| X | 0' | 10' | 20' | 30' | 40' | 50' | 60' | 70' |
| Y | 0.00' | 0.20' | 0.80' | 1.80' | 3.20' | 5.00' | 7.00' | 9.00' |

| | | | | | | | |
|--------|--------|--------|--------|--------|--------|--------|--------|
| 80' | 90' | 100' | 110' | 120' | 130' | 140' | 150' |
| 11.00' | 13.00' | 15.00' | 16.80' | 18.20' | 19.20' | 19.80' | 20.00' |

NOTE :

IN THE CASE WHEN THE BASELINE IS CURVED THE OFFSETS ARE CALCULATED BY ASSUMING THE BASELINE TO BE A TANGENT, THEN THEY ARE APPLIED TO THE CURVED BASELINE. AB' AND C'D' ARE NO LONGER PARABOLIC AND B'C' IS NO LONGER TANGENT.

REVISIONS

CITY OF FOUNTAIN VALLEY

STANDARD
PLAN NO.

PARABOLIC CURB TRANSITION
FOR LEFT TURN POCKETS

111

APPROVED BY: 
MARK LEWIS R.C.E. 49335
CITY ENGINEER

DATE: 06/03/03

SHEET: 1 OF 1

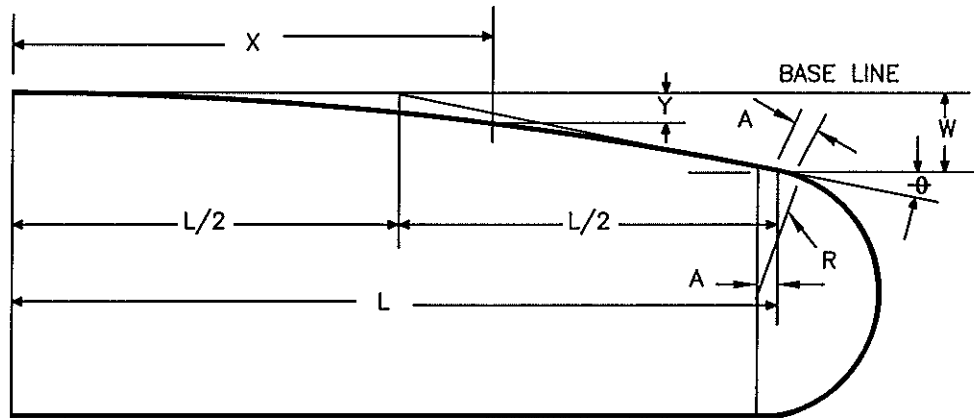

$$Y = W(X/L)^2$$

$$\tan \theta = 2W/L$$

$$A = R(\tan \theta / 2)$$

L = LENGTH OF FLARE IN FEET
 W = MAXIMUM OFFSET DISTANCE IN FEET
 X = DISTANCE ALONG BASE LINE IN FEET

A = TANGENT
 R = RADIUS OF NOSE IN FEET
 Y = OFFSET FROM BASE LINE IN FEET

OFFSET "Y" (IN FEET)
 FOR W/L = 1:10

| L \ X | 10 | 20 | 30 | 40 | 50 | 60 | 70 | 80 | 90 | 100 |
|-------|-----|-----|------|------|------|------|------|------|------|-------|
| 60 | .17 | .67 | 1.50 | 2.67 | 4.17 | 6.00 | — | — | — | — |
| 100 | .10 | .40 | .90 | 1.60 | 2.50 | 3.60 | 4.90 | 6.40 | 8.10 | 10.00 |

NOTE:

- FOR 60' FLARE, USE R = 4' (14'-16' MEDIAN)
- IF STATION OF RADIUS POINT IS NOT GIVEN ON PLAN, TANGENT 'A' MAY BE IGNORED

REVISIONS

CITY OF FOUNTAIN VALLEY

PARABOLIC MEDIAN CURB FLARE

STANDARD
PLAN NO.

112

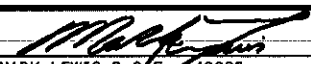
APPROVED BY:  MARK LEWIS R.C.E. 49335
CITY ENGINEER

DATE: 06/03/03

SHEET: 1 OF 1

SPECIFICATIONS FOR EXPOSED AGGREGATE CONCRETE PAVING

1. EXPOSED AGGREGATE FINISH CONCRETE PAVING SHALL BE INSTALLED ON MEDIANS WHERE "W" IS LESS THAN 6'-0".
2. A 4' X 4' X 4" SAMPLE SHALL BE BE PLACED ON-SITE AND SHALL REMAIN UNTIL COMPLETION AND APPROVAL OF THE WORK.
3. CONCRETE SHALL HAVE 2000 PSI AT 28 DAYS, 7 SACK TYPE II OR 6 SACK TYPE V CEMENT UNLESS DEEMED UNNECESSARY BY SULFATE CONTENT TESTS AS APPROVED BY THE CITY ENGINEER. CONCRETE SHALL NOT EXCEED 4" SLUMP.
4. AGGREGATE MIX SHALL CONSIST OF 30 PERCENT SANTIAGO SAND AND 70 PERCENT PEA ROCK.
5. CONCRETE SHALL BE REINFORCED BY 6" x 6" - W1.4 x W1.4 WWF (10 GAUGE) THROUGHOUT.
6. INSTALLATION PROCEDURE:
 - A. DO NOT USE CONCRETE PUMP FOR INSTALLATION.
 - B. SCREED CONCRETE WITHOUT TAMPING.
 - C. FLOAT, FRESNO, AND EDGE CONCRETE.
 - D. WHEN WATER LEAVES SURFACE, FRESNO OR TROWEL AND EDGE CONCRETE REMOVING RIDGES LEFT FROM INITIAL TOOLING.
 - E. SPRAY ON CONCRETE RETARDANT COATING.
 - F. ONE HOUR AFTER SPRAYING, COVER WITH PLASTIC VISQUEEN TO KEEP MOISTURE ON SURFACE.
 - G. 12 TO 24 HOURS LATER, WASH SURFACE AND STIFF BROOM TO REMOVE RETARDANT MORTAR WHICH WILL EXPOSE AGGREGATE.
 - H. CLEAN RESIDUAL CEMENT FROM EXPOSED AGGREGATE WITH A LIGHT ACID WASH AFTER 28 DAYS CURING.
7. EXPANSION JOINTS SHALL BE EQUALLY SPACED NOT TO EXCEED 10' ON CENTER. CONTROL JOINTS SHALL BE EQUALLY SPACED NOT TO EXCEED 5' ON CENTER.
8. ALL FINISH SURFACES AND GRADES SHALL SLOPE TO DRAIN.
9. CONTRACTOR SHALL NOTIFY CITY 48 HOURS PRIOR TO THE COMMENCEMENT OF CONSTRUCTION.
10. PRE-EMERGE WEED KILLER MUST BE USED PRIOR TO CONSTRUCTION OF PCC FLATWORK.

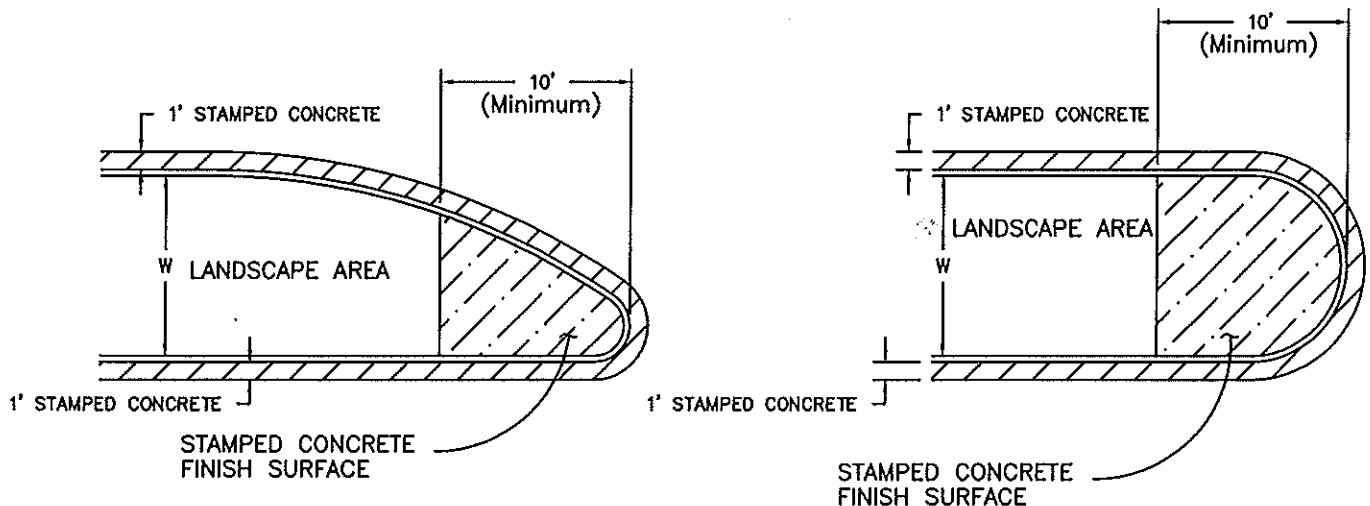

| | | |
|-----------|--|-------------------|
| REVISIONS | CITY OF FOUNTAIN VALLEY | STANDARD PLAN NO. |
| | MEDIAN NOSE PAVING DETAIL | 113 |
| | APPROVED BY: MARK LEWIS R.C.E. 49335 CITY ENGINEER | DATE: 06/03/03 |
| | | SHEET: 1 OF 1 |

CURVE DATA ON NOSE CURVE

≈ 157°22'48"

R=1.89'
L=5.19'
T=9.45'

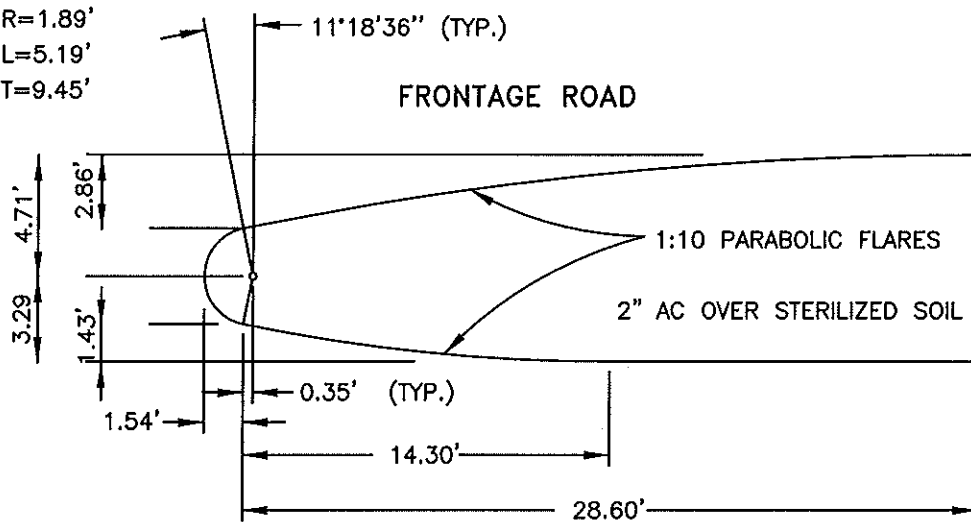

ARTERIAL HIGHWAY

REVISIONS

CITY OF FOUNTAIN VALLEY

STANDARD
PLAN NO.

FRONTAGE ROAD MEDIAN ISLAND NOSE

114

APPROVED BY: 
MARK LEWIS R.C.E. 49335
CITY ENGINEER

DATE: 06/03/03

SHEET: 1 OF 1

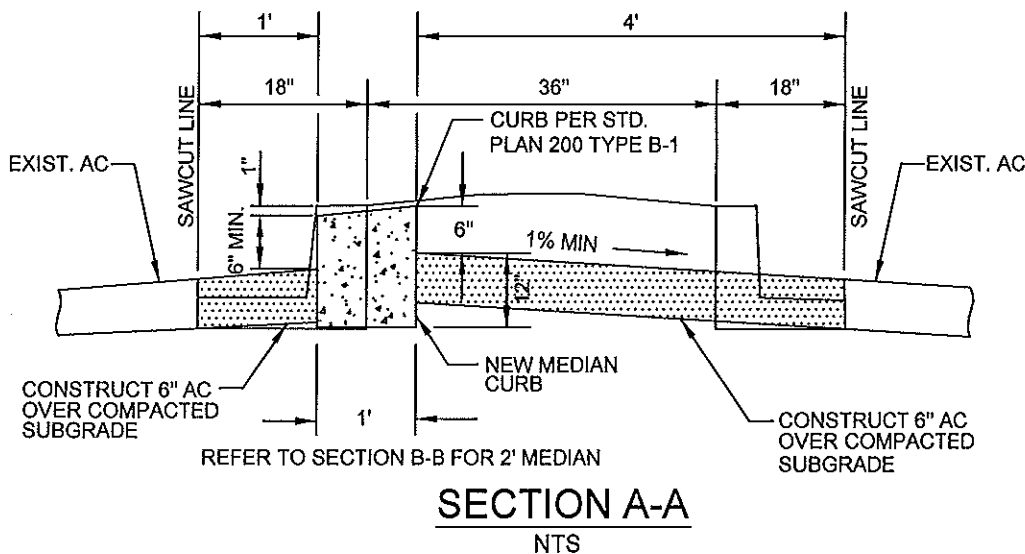
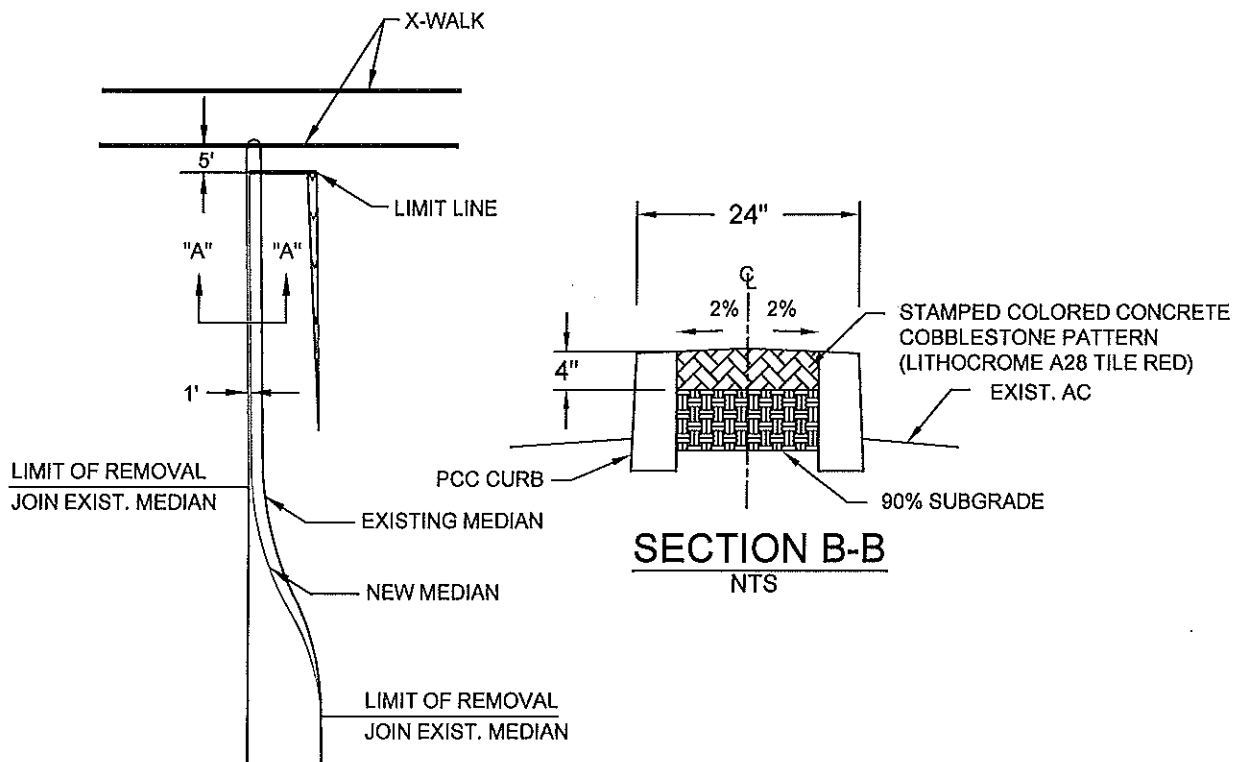

DETAIL "A"
MEDIAN REMOVAL AND
CONSTRUCTION DETAIL
 NTS

REVISIONS

11/18/10

CITY OF FOUNTAIN VALLEY

MEDIAN CURB

STANDARD
PLAN NO.

115-1

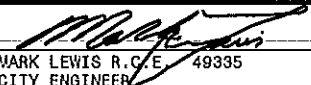
APPROVED BY:  MARK LEWIS R.C.E. 49335
CITY ENGINEER

DATE: 06/03/03

SHEET: 1 OF 2

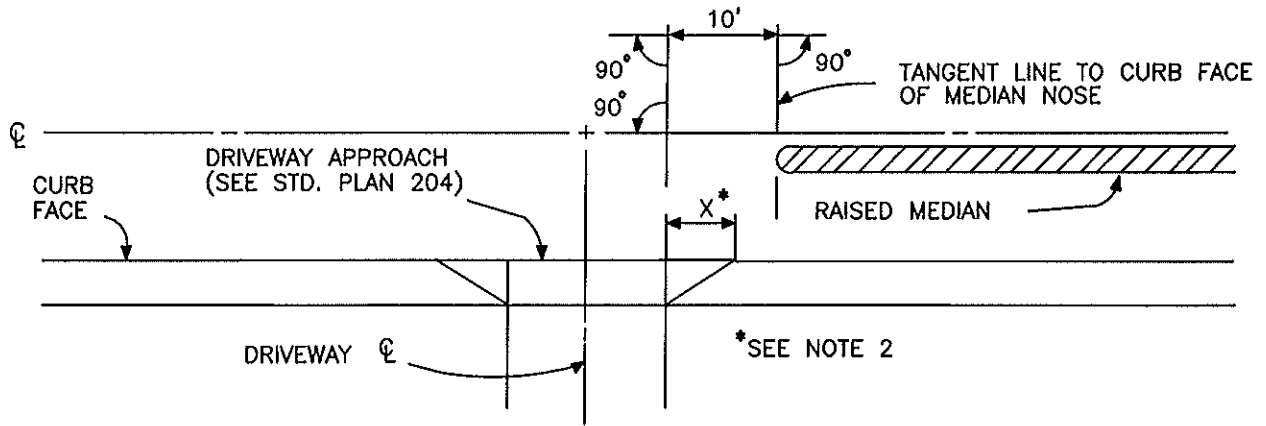

RIGHT ANGLE INTERSECTION (DRIVEWAY)

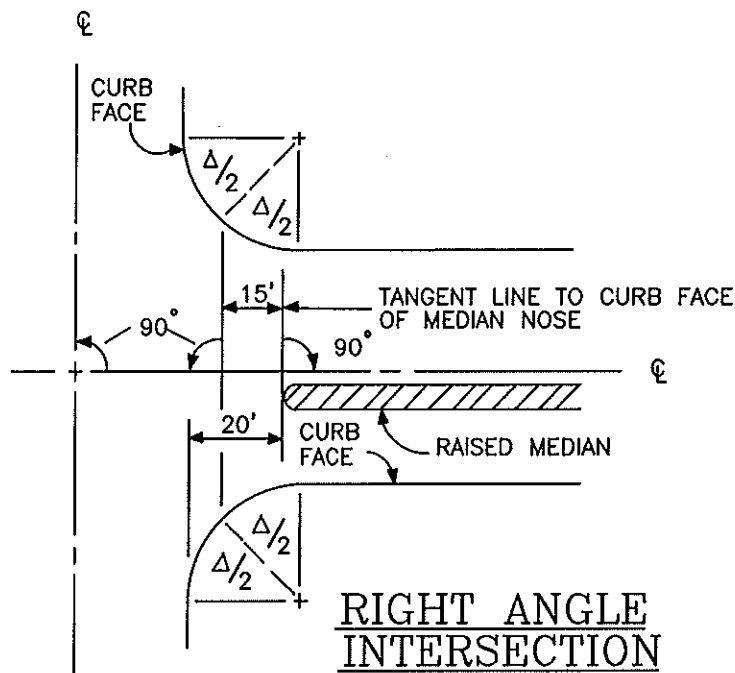

NOTES

1. EXTEND DOUBLE YELLOW STRIPING FROM MEDIAN NOSE TO CROSSWALK OR TO $\Delta/2$ IF THERE IS NO CROSSWALK.
2. "X" SHALL BE 3' FOR 6" CURB, 4' FOR 8" CURB.
3. FOR CROSSWALK LOCATIONS, SEE STD. PLAN 202.

REVISIONS

CITY OF FOUNTAIN VALLEY

STANDARD
PLAN NO.

RAISED MEDIAN NOSE LOCATION

115-2

APPROVED BY:  MARK LEWIS R. C.E. 49335
CITY ENGINEER

DATE: 06/03/03

SHEET: 2 OF 2

CONCRETE CLASS USE TABLE

| CONSTRUCTION | CONCRETE CLASS | MAX. SLUMP | EQUIV. SACK MIX |
|---|----------------|------------|-----------------|
| STREET SURFACE IMPROVEMENTS | | | |
| CONCRETE PAVEMENT (not integral with curb) | 520-A-2500 | 3" | 5.5 |
| CURB, INTEGRAL CURB & PAVEMENT, GUTTER, WALK, ALLEY APRONS, MEDIAN NOSE | 520-C-2500 | 4" | 5.5 |
| EXTRUDED CURB, CURB & GUTTER | 520-C-2500 | 1.5" | 5.5 |
| | 520-D-2500 | 1.5" | 5.5 |
| SEWER & STORM DRAINAGE FACILITIES | | | |
| PIPE COLLARS, BEAM SUPPORT FOR PIPE, PRE-CAST MANHOLE COMPONENTS, CATCH BASINS, SIDEWALK CULVERTS | 560-C-3250** | 5" | 6 |
| SIDEHILL SURFACE DRAINAGE FACILITIES | 500-C-2500 | 3" | 5.5 |
| PIPE BEDDING & ENCASEMENT*, ANCHORS & THRUST BLOCKS, WALL SUPPORT FOR PIPE | 420-C-2000** | 4" | 4.5 |
| TUNNEL BACKFILL | 480-C-2000 | 5" | 5 |
| TRENCH BACKFILL SLURRY | 100-E-100 | 5" | 1 |
| REINFORCED STRUCTURES | | | |
| BRIDGES, BUILDINGS, RETAINING WALLS | 560-C-3250** | 4" | 6 |
| CAST-IN-PLACE PILES | 560-C-3250** | 4" | 6 |
| CHANNELS & BOXES | | | |
| INVERT | 560-B-3250 | 4" | 6 |
| WALLS & DECK | 560-C-3250 | 5" | 6 |
| MISCELLANEOUS | | | |
| STREET LIGHT & TRAFFIC SIGNAL FOUNDATIONS, SURVEY MONUMENTS | 560-C-3250 | 4" | 6 |
| FENCE & GUARDRAIL POST FOUNDATIONS | 500-C-2500 | 5" | 5.5 |
| CONCRETE NOT OTHERWISE SPECIFIED | 560-C-3250 | 5" | 5.5 |
| AIR PLACED CONCRETE, METHOD B | 600-E-3250 | 4" | 6.5 |

*USE LIMITED TO BEDDING CONCRETE OVER WHICH BACKFILL WILL BE PLACED NOT LESS THAN 40 HOURS AFTER PLACEMENT. FOR BACKFILL AFTER 24 HOURS, ADD 3 PINTS (1.4L) OF CALCIUM CHLORIDE. FOR BACKFILL AFTER 16 HOURS & REMOVAL OF SHEETING AFTER 18 HOURS. USE 660-C-3750 WITH 3 PINTS (1.4L) CALCIUM CHLORIDE SOLUTION.

**USE B AGGREGATE GRADUATION WHEN CONDITIONS PERMIT.

FOR AGGREGATE GRADUATION SEE STANDARD SPECIFICATIONS FOR PUBLIC WORKS CONSTRUCTION. CURRENT EDITION.

TYPE V-CEMENT (6-SACK) SHALL BE USED FOR ALL CONCRETE IN CONTACT WITH SOIL HAVING A HIGH SULFATE CONTENT OR AS SPECIFIED BY THE SOILS ENGINEER.

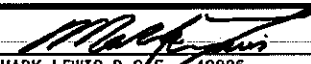
| | | |
|-----------|--|-------------------|
| REVISIONS | CITY OF FOUNTAIN VALLEY | STANDARD PLAN NO. |
| | CONCRETE CLASS USE TABLE | 116 |
| |  APPROVED BY: MARK LEWIS R.C.E. 49336 CITY ENGINEER | SHEET: 1 OF 1 |
| | DATE: 06/03/03 | |

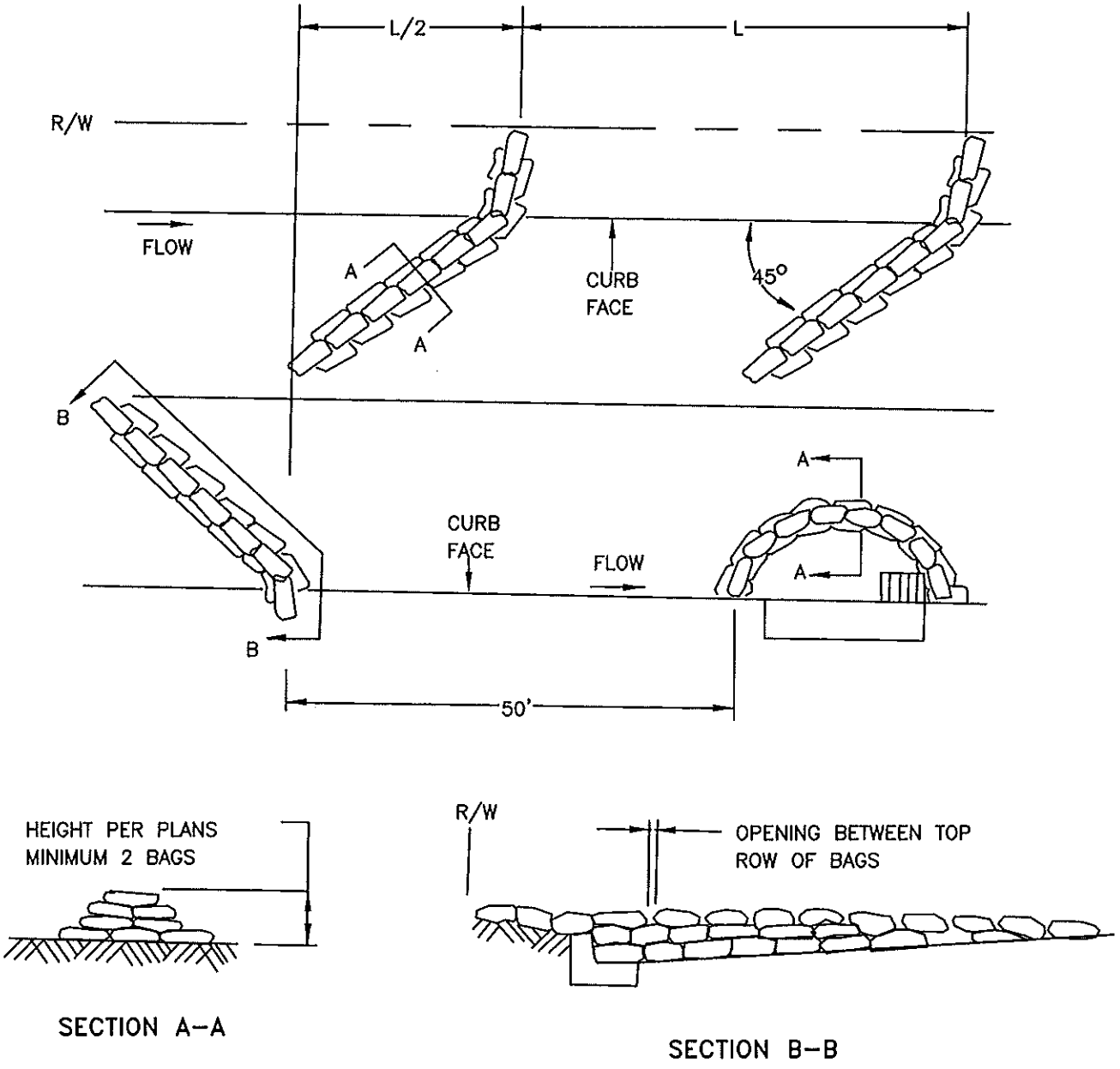

SEE STANDARD PLAN 119 FOR NOTES AND A SCHEDULE FOR DIMENSION L.

| | | |
|--|--|--|
| REVISIONS | <h2 style="margin: 0;">CITY OF FOUNTAIN VALLEY</h2> <h3 style="margin: 0;">STREET DESILTING SANDBAGGING</h3> | STANDARD PLAN NO. 117 |
| APPROVED BY:  MARK LEWIS R.C.E. 49335 CITY ENGINEER | | |

DATE: 06/03/03

$\Delta = 15' 11' 22''$
 $R = 171.75'$
 $L = 45.53'$
 $T = 22.90'$

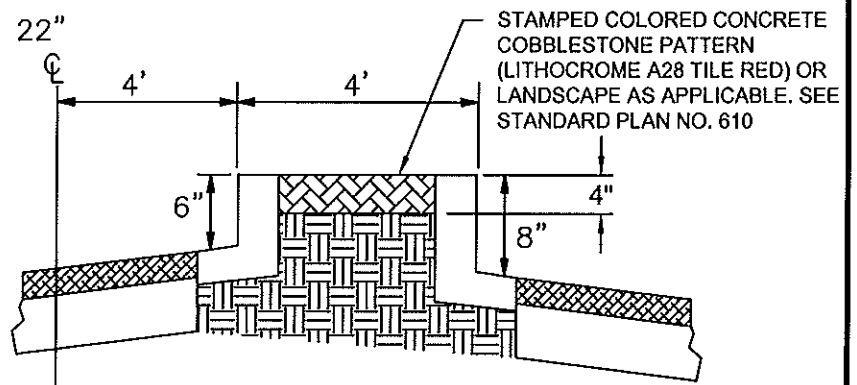

SECTION A-A

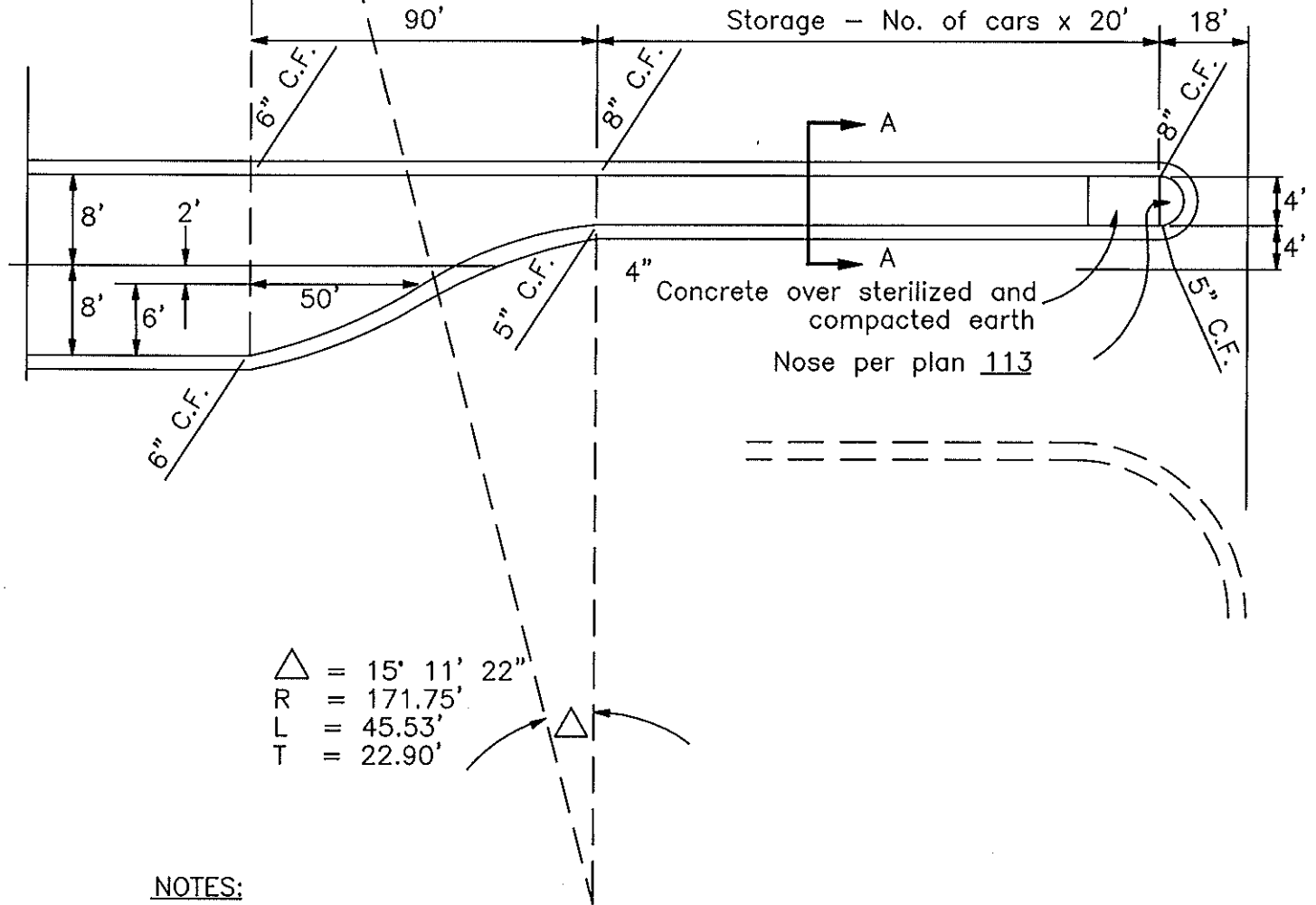

$\Delta = 15' 11' 22''$
 $R = 171.75'$
 $L = 45.53'$
 $T = 22.90'$

NOTES:

1. When the median is to be paved with 2" A.C., the soil shall be compacted to 90% and sterilized with polyborchlorate at an application rate of 4 pounds per 100 square feet. The soil shall be in a moist condition prior to the application of the sterilant.
2. The soil within the median shall be removed to 20 inches below the top of the median curb and shall be replaced with soil free of deleterious material to 2 inches below the top of curb.

REVISIONS

06/08/06

CITY OF FOUNTAIN VALLEY

DIVIDER MEDIAN

STANDARD
PLAN NO.

118

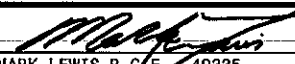
APPROVED BY: 
MARK LEWIS R.C.E. 49335
CITY ENGINEER

DATE: 06/03/03

SHEET: 1 OF 1

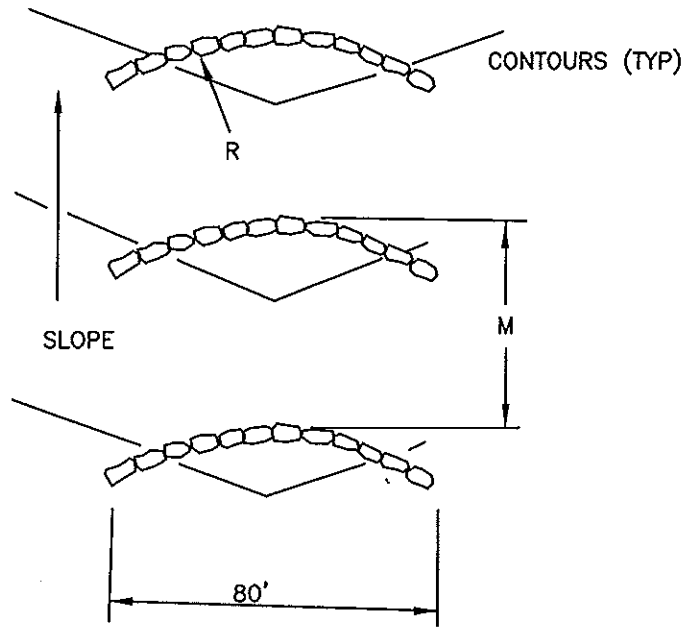

1. GRAVEL BAGS ARE ENCOURAGED OVER THE USE OF SAND BAGS AND MAY BE REQUIRED IN PROBLEM AREAS.
2. STREETS SANDBAGGED PER THE LAYOUT IN STANDARD PLAN 117 OR 118 SHALL NOT BE OPEN TO THE PUBLIC.

| GRADE | R | M | L |
|---------|------|------|------|
| <4% | 100' | 200' | 200' |
| 4 TO 9% | 100' | 200' | 100' |
| >9% | 80' | 150' | 50' |

REVISIONS

CITY OF FOUNTAIN VALLEY

SWALE SANDBAG VELOCITY REDUCERS

STANDARD
PLAN NO.

119

APPROVED BY: 
MARK LEWIS R.C.E. 49335
CITY ENGINEER

DATE: 06/03/03

SHEET: 1 OF 1

CASE I

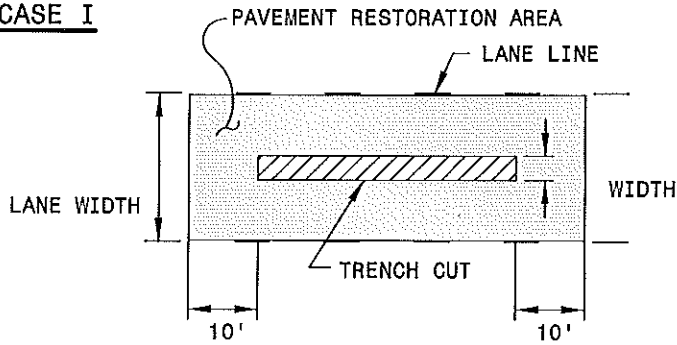

NOTES

1. TRENCH CUT IN DIRECTION OF TRAVEL
2. COLD MILL 0.12' (MIN.) FROM LANE LINE TO LANE LINE.

CASE IV

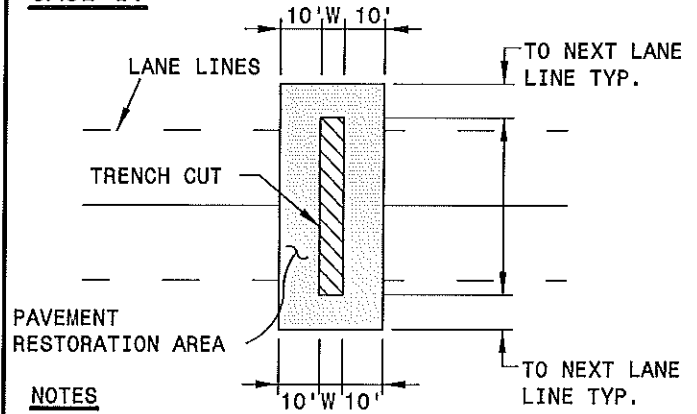

NOTES

1. TRENCH CUT NORMAL OR PERPENDICULAR TO DIRECTION OF TRAVEL.
2. W: 1.0' TRENCH WIDTH MIN.

CASE II

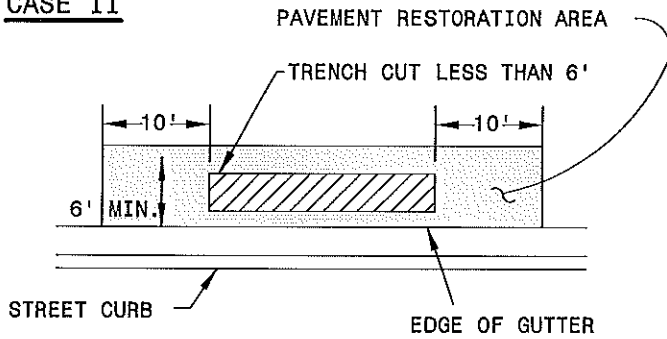

NOTES

1. TRENCH CUT DIRECTION ABUTTING EDGE OF GUTTER ON RESIDENTIAL/INDUSTRIAL/COLLECTOR STREET.
2. FOR TRENCH GREATER THAN 6' IN WIDTH OR FOR A TRENCH THAT EXTENDS BEYOND 6' FROM EDGE OF GUTTER, REPAVING OF 1/2 STREET WIDTH FOR ENTIRE LENGTH OF TRENCH IS REQUIRED.

CASE V

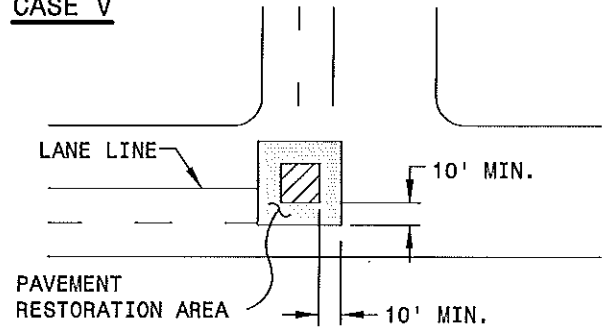

NOTES

1. TRENCH CUT OR POTHOLE GREATER THAN 3' IN ANY DIRECTION.

CASE III: PAVEMENT MORATORIUM STREETS

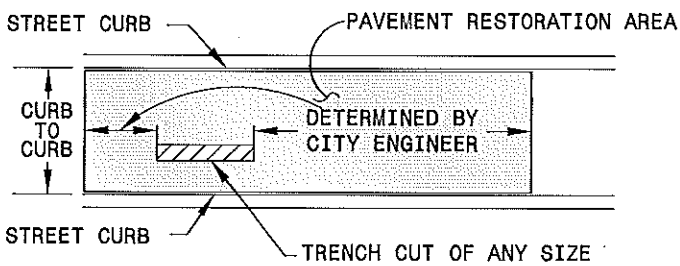

NOTES

1. REGARDLESS OF TRENCH SIZE, CURB TO CURB PAVEMENT RESTORATION IS REQUIRED FOR ALL PUBLIC STREETS UNDER PAVEMENT MORATORIUM.

REVISIONS

11/18/10

CITY OF FOUNTAIN VALLEY

**STREET ASPHALT PATCHING
FOR TRENCH EXCAVATIONS**

**STANDARD
PLAN NO.**

120

APPROVED BY: *Mark Lewis*
MARK LEWIS R.C.E. 49335
CITY ENGINEER

DATE: 06/03/03

SHEET: 1 OF 1

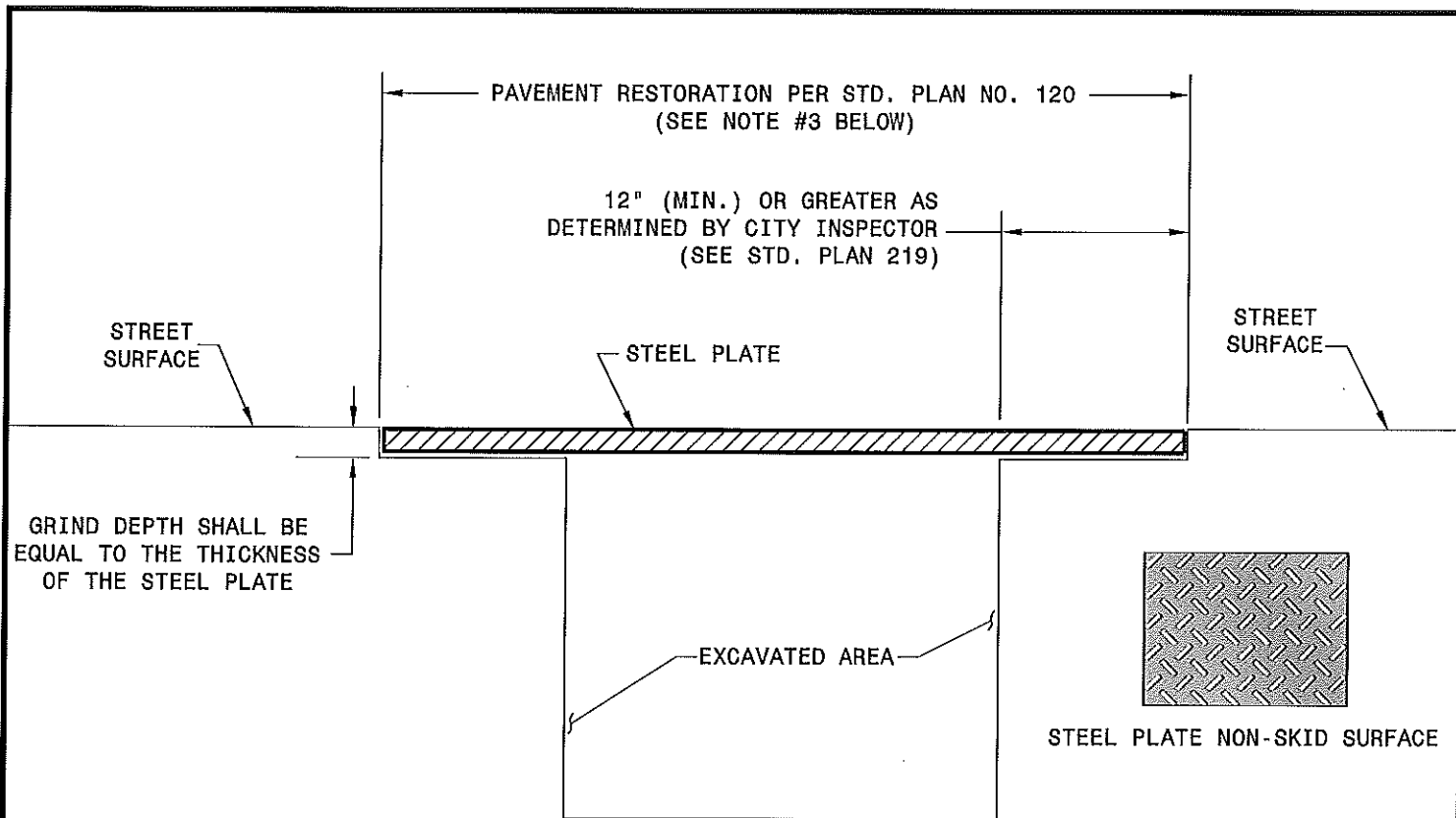

CROSS SECTION VIEW

NO SCALE

NOTES:

1. IF THE GAP BETWEEN THE STREET SURFACE AND THE STEEL PLATE EXCEEDS 1", THE GAP SHALL BE FILLED WITH COLD PATCH ASPHALT.
2. THE EXCAVATION AREA SHALL BE BACKFILLED PER STANDARD PLAN NO. 219.
3. THE PAVEMENT SHALL BE RESTORED WITHIN 5 WORKING DAYS OF THE COMPLETION OF THE PERMITTED WORK PER STANDARD PLAN NO. 120.
4. WHEN TWO OR MORE PLATES ARE USED, THE PLATES SHALL BE TACK WELDED AT EACH CORNER OR AS REQUIRED BY THE CITY.
5. BY THE CITY.
6. ALL TRENCH PLATES SHALL HAVE A NON-SKID SURFACE AS APPROVED BY CITY INSPECTOR. MINIMUM THICKNESS OF PLATES SHALL BE 1" IN STREETS, DRIVEWAYS, AND PARKING LANES. FOR TRENCH WIDTHS GREATER THAN 4', PLATE THICKNESS SHALL BE 1-1/4", AND CENTER SUPPORTS SHALL BE USED BASED ON AN ENGINEERING ANALYSIS PROVIDED BY THE DEVELOPER AND APPROVED BY THE CITY ENGINEER. STEEL PLATES LESS THAN 1" IN THICKNESS MAY ONLY BE USED IN NON-VEHICLE AREAS.
7. PLATES SHALL NOT BE LEFT OVER A WEEKEND WITHOUT PRIOR APPROVAL BY THE CITY.

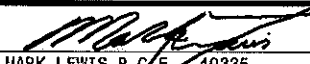
| | | |
|-----------|---|-------------------|
| REVISIONS | CITY OF FOUNTAIN VALLEY | STANDARD PLAN NO. |
| | STEEL PLATE BENCHING DETAIL | |
| 11/18/10 | | 121 |
| |  APPROVED BY: MARK LEWIS R.C.E. 49335 CITY ENGINEER | DATE: 06/03/09 |
| | | SHEET: 1 OF 1 |